

MAINTENANCE MANUAL NO. MM-0350

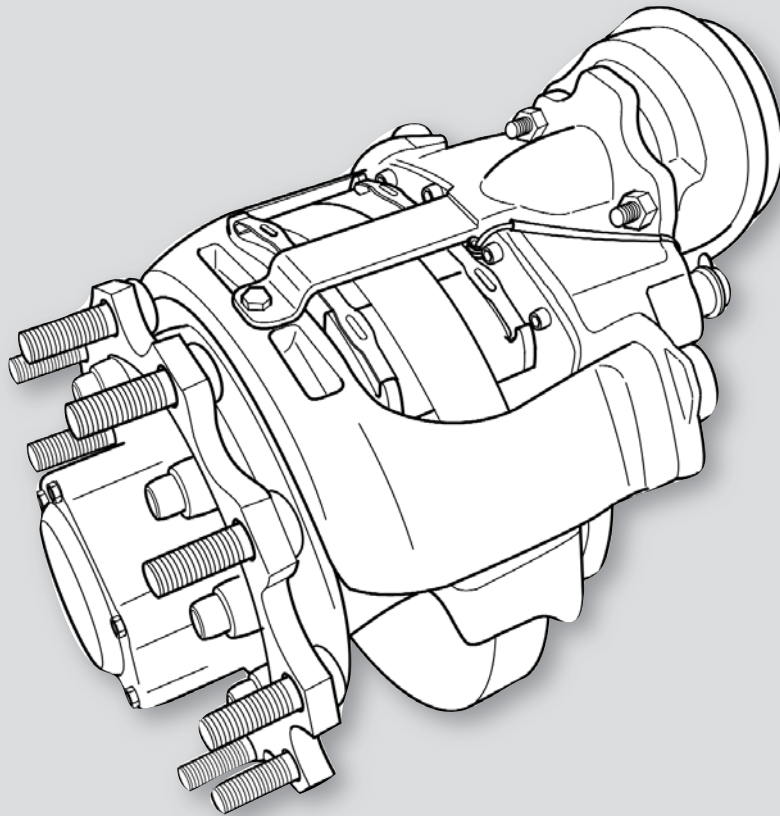

**Meritor Inc. Air Disc Brake
Service Manual
ELSA 195, 225 & 250**

Issued: 11/2016



All rights reserved.

No part of this publication may be reproduced in any form or by any means or granted to any third parties without the written permission of MERITOR Inc..

Information contained in this publication was in effect at the time the publication was approved for printing and is subject to change without notice or liability. MERITOR Inc. Commercial Vehicle Systems reserves the right to revise the information presented and to discontinue the production of parts described at any time.

© 2016 MERITOR Inc.
Document No. MM-0350
Edition: 11/2016

Before You Begin

This publication provides installation and maintenance procedures for the ELSA 195/225/250 range of Reaction Beam Air Disc Brakes. The information contained in this publication was current at the time of printing and is subject to revision without notice or liability.

The designated trademarks are registered marks of their respective owners and MERITOR Inc. and its affiliates are not commercially connected, affiliated, or associated with any of the owners of such marks. The MERITOR Inc. products presented herein are not endorsed or authorized by any of the trademark owners.

You must understand all procedures and instructions before you begin maintenance and service procedures.

You must follow your company's maintenance and service guidelines.

You must use special tools, when required, to avoid serious personal injury and damage to components.

MERITOR Inc. uses the following notations to alert the user of possible safety issues and to provide information that will help to prevent damage to equipment and components.



WARNING

A **WARNING** indicates a procedure that you must follow exactly to avoid serious personal injury.



CAUTION

A **CAUTION** indicates a procedure that you must follow exactly to avoid damaging equipment or components. Serious personal injury can also occur.

NOTE: A note indicates an operational, procedure or instruction that is important for proper service. A NOTE can also supply information that will help to make service quicker and easier.



This symbol indicates that you must tighten fasteners to a specific torque.

Safety Instructions

- Observe the manufacturers safety instructions for jacking up and securing the vehicle
- Only use original MERITOR Inc. parts
- Use only the tools recommended
- Observe the following service instructions and notes
- Always ensure appropriate safety glasses and gloves are worn when carrying out the procedures detailed in this publication.
- When working on the brake you must ensure that it cannot be activated inadvertently
- Never use compressed air to remove brake dust or for the purpose of drying. Any type of dust can be injurious to health if inhaled. Use Meritor CVA. brake cleaner for cleaning the brake.
- When removing or fitting a complete brake, you should remember it has a dead weight of up to 108lbs (49 kg). Use a lifting system, taking care not to damage the brake.
- When the servicing has been completed, it is essential that you road test the vehicle and try out the brakes.



CAUTION: Ensure any grease removed from the assembly/components, or contaminated cloth, is disposed of in accordance with local environmental regulations.



CAUTION: You must always renew the brake pads on both wheels of an axle. Only use the brake pads that have been approved by the vehicle manufacturer.



CAUTION: Ensure any discarded friction product, or cloth contaminated with brake dust, is disposed of in accordance with local environmental regulations.



CAUTION: You must always renew the rotor on both wheels of an axle. Only use the rotors that have been approved by the vehicle manufacturer.

Service Notes

Service Manual Issue Update Detail

The table below provides a brief description of the changes made from the previous (10/2015) edition of the service manual;

| Date | Update | Page |
|-----------|--|--|
| 01 / 2014 | Caution - Piston housing screw removal. | 3,19, 54 |
| | Exploded Views and Annotations | 8 to 18 |
| | Revised Service diagnosis section | 88 |
| 07 / 2014 | New exploded view - 225H with cartridge wear sensor | 16 |
| | New NOTE regarding alternative wear sensors | 21, 50, 52, 56 & 59 |
| | New CAUTION regarding visual wear indicator check for seizure | 31 |
| | Pad Shield reference | 37, 38, 40 & 44 |
| | New CAUTION regarding Pad location | 39 |
| | Rotor Shield reference | 50 & 51 |
| | Visual Wear Indicator replacement | 56 |
| | End Cap replacement | 58 |
| | New Section 11 - Guide Sleeve. Including alternative bush replacement procedures | 69 - 83 |
| | New Torque values | 90 |
| | New service tool MST 1060 | 96 |
| | New Supplement 2 - Cartridge Continuous Wear Sensor | 115 - 126 |
| | 03 / 2015 | Supplement 2 - Section 2.2 updated to include removal and refitting original sensor assembly |
| 10 / 2015 | New Torque values | 90 |

| Date | Update | Page |
|-----------|--|------------|
| 11 / 2016 | Revised exploded view and parts list to include tangential carrier | 16, 17 |
| | Revised pad wear check information | 31 |
| | Revised Section 5, Alternative retaining screw lengths | 48 |
| | New Caution regarding actuator torque | 50 |
| | New Note regarding actuator support | 50, 56, 62 |
| | New Note regarding dowel bushes | 51 |
| | New Note regarding guide sleeves | 62, 63 |
| | Procedure change; CWS removed before the air chamber | 56, 62 |
| | Revised Section 11 to include ball bearing guide sleeve alternatives | 69 |
| | New section 12 for carrier dowel bush replacement | 85 |
| | Revised guide sleeve Torque values, section 14 | 94 |

Access Information on MERITOR Inc.'s Web Site

Additional maintenance and service information for MERITOR Inc.'s commercial vehicle systems component lineup is also available at www.meritor.com.

To access information go to Products & Services Icon; from drop down menu click on Literature on Demand. The screen will display an index of publications by type.

Terms used in this manual

Manufacturer:

MERITOR Inc.

Manual:

Maintenance manual no. MM-0350

Device:

ELSA Reaction Beam Air Disc Brake
(Eccentric Lever **Side Actuation**)

Technician:

Qualified personnel working on brake maintenance and servicing.

Maintenance and servicing:

Maintenance and servicing refer to periodical checks and/or replacement of air disc brake parts or components. It also refers to the determining of the cause of a malfunction in order to restore the initial operating conditions.

Operator:

Any person who will use the air disc brake as part of a more complex device.

Warranty

Warranty applies to the air disc brake installed on vehicles for which it was designed. Warranty is void in the following cases:

- Improper use of the vehicle on which the air disc brake is installed (usage conditions, overloading etc.)
- Tampering with vehicle components that may affect brake performance.
- Use of spare parts not approved by Meritor CVS.
- Improper installation, adjustment, repair or modification.
- Poor or improper maintenance (including consumables other than those specified).

Further information on warranty conditions may be obtained directly from the manufacturer or by referring to the MERITOR Inc. web site www.meritor.com

NOTE: The exploded and section views contained in this manual are for reference only. The internal components are not serviceable



CAUTION: The screws **A**, shown below, which secure the piston housing to the brakes assembly housing **MUST NOT** be removed. Evidence of tampering with the screws will void any warranty claim.

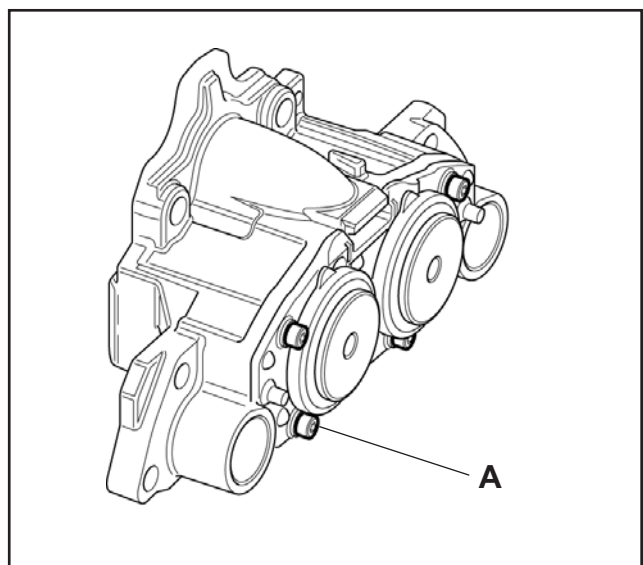

Contents

Section 1: Introduction

- pg. 8 Radial brake - exploded view
- pg. 9 Portal brake - exploded view
- pg. 10 Radial & Portal brakes - parts list
- pg. 11 Axial brake 195 - exploded view
- pg. 12 Axial brake 225L & 225H - exploded view
- pg. 13 Axial brake 225E - exploded view
- pg. 14 Axial brake EX225L - exploded view
- pg. 15 Axial brake 250 - exploded view
- pg. 16 Axial brake 225H (with cartridge sensor) - exploded view
- pg. 17 Axial brakes - parts list
- pg. 18 Housing assembly - cross section
- pg. 19 Brake body detail - cross section
- pg. 18 Cross sections - Parts List
- pg. 20 How it works
- pg. 21 Automatic adjustment
- pg. 22 Manual adjustment and de-adjustment
- pg. 23 Actuator

Section 2: Operational Checks

- pg. 26 Automatic adjuster test
- pg. 28 Sliding action Check
- pg. 28 Slide pin wear check
- pg. 31 Pad wear
- pg. 33 Rotor checks

Section 3: Pad Replacement

- pg. 36 Pad retaining plate removal (with PWWI fitted)
- pg. 38 Pad removal
- pg. 38 Cleaning and Inspection
- pg. 39 Fitting new pads

Section 4: Pad Retaining Plate Replacement

- pg. 44 Pad retaining plate removal
- pg. 45 Pad retaining plate fitment

Section 5: CWS (Sensor/Switch) Replacement

- pg. 48 CWS removal & fitment

Section 6: Brake Replacement

- pg. 50 Brake removal
- pg. 51 Brake fitment
- pg. 51 Actuator Seal Replacement

Section 7: Bridge Replacement

- pg. 54 Removing & fitting the bridge

Section 8: Housing & Visual Wear Indicator Replacement

- pg. 56 Removing the housing assembly
- pg. 56 Removing or retaining the visual wear indicator
- pg. 57 Fitting the visual wear indicator
- pg. 57 Fitting housing assembly
- pg. 58 Fitting new end caps

Section 9: Carrier Replacement

- pg. 62 Carrier removal
- pg. 63 Carrier fitment

Section 10: Piston Head & Dust Excluder Replacement

- pg. 66 Piston Dust Excluder Removal
- pg. 66 Piston Head Replacemet
- pg. 67 Fitting Dust Excluder

Section 11: Guide Sleeve, Dust Excluder, Retainer & Bush Replacement

- pg. 70 Guide sleeve bush & retainer description
- pg. 71 Guide sleeve bush & retainer replacement - Using Meritor CVA Service Tool MST 1060
- pg. 76 Guide sleeve bush & retainer replacement - Using Alternative Tooling
- pg. 80 Removing guide sleeves & guide sleeve dust excluders
- pg. 81 Fitting new guide sleeves & dust excluders
- pg. 82 Fitting new end caps

Section 12: Carrier Dowel Bush Replacement

pg. 86 Dowel bush removal

pg. 86 Dowel bush fitment

Section 13: Rotor Re-work & Replacement

pg. 90 Elsa 195,225 & 250 Rotor rework & replacement

Section 14: Servicing and Specifications

pg. 94 Servicing schedules, Tightening Torque's

pg. 94 Grease specification.

Section 15: Service Diagnosis

pg. 98 Service diagnosis

Section 16: Special Tools

pg. 102 MST 1060 Guide Sleeve Bush removal/fitting tool

pg. 103 MST 1017 Slide Pin Wear Tool

Supplement 1 Tangential Adaptor Assembly

Section S1.1: Introduction

pg. 110 Exploded View & Parts List

pg. 111 Section View & Parts List

pg. 112 How it works

Section S1.2: Adaptor Assembly Replacement

pg. 114 Assembly Removal

pg. 114 Assembly Fitment

Section S1.3: Actuator & Secondary Seal Replacement

pg. 118 Actuator Seal Replacement

pg. 119 Secondary Seal Replacement

Supplement 2 Cartridge CWS (wear sensor)

Section S2.1: Introduction

pg. 126 Exploded View & Parts List

pg. 127 Introduction

pg. 127 How it Works

Section S2.2: CWS Assembly Removal & Replacement

pg. 130 Removing and Refitting the Original Sensor

pg. 131 Original Sensor Replacement

Introduction

1

- pg. 8 Radial brake - exploded view
- pg. 9 Portal brake - exploded view
- pg. 10 Radial & Portal brakes - parts list
- pg. 11 Axial brake 195 - exploded view
- pg. 12 Axial brake 225L & 225H - exploded view
- pg. 13 Axial brake 225E - exploded view
- pg. 14 Axial brake EX225L - exploded view
- pg. 15 Axial brake 250 - exploded view
- pg. 16 Axial brake 225H - exploded view
- pg. 17 Axial brakes - parts list
- pg. 18 Housing assembly - cross section
- pg. 19 Brake body detail - cross section
- pg. 18 Cross sections - Parts List
- pg. 20 How it works
- pg. 21 Automatic adjustment
- pg. 22 Manual adjustment and de-adjustment
- pg. 23 Actuator

Exploded View - Typical Radial Brake Assembly

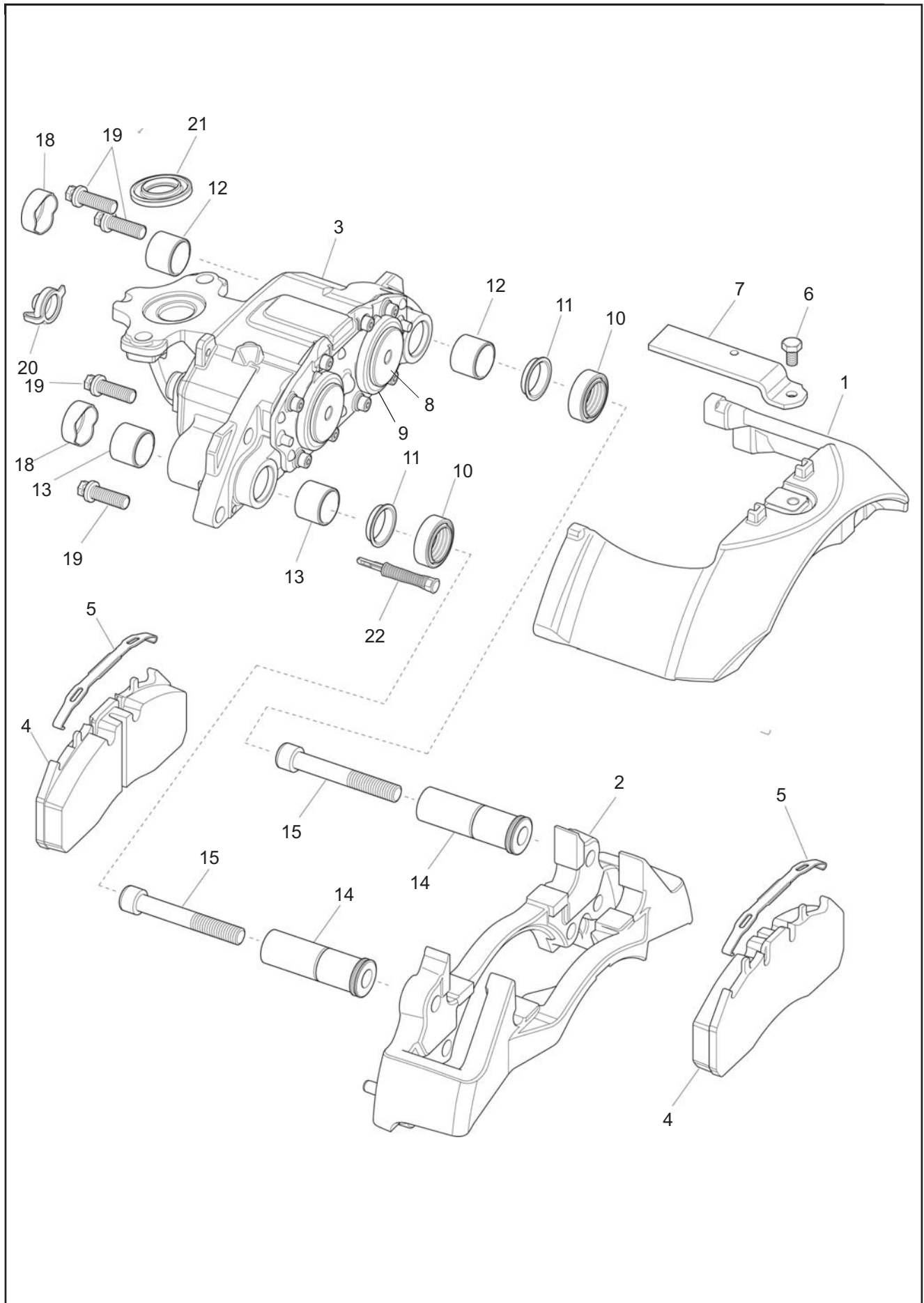

Fig 1.1a

Exploded View - Typical Portal Brake Assembly (Bus Applications)

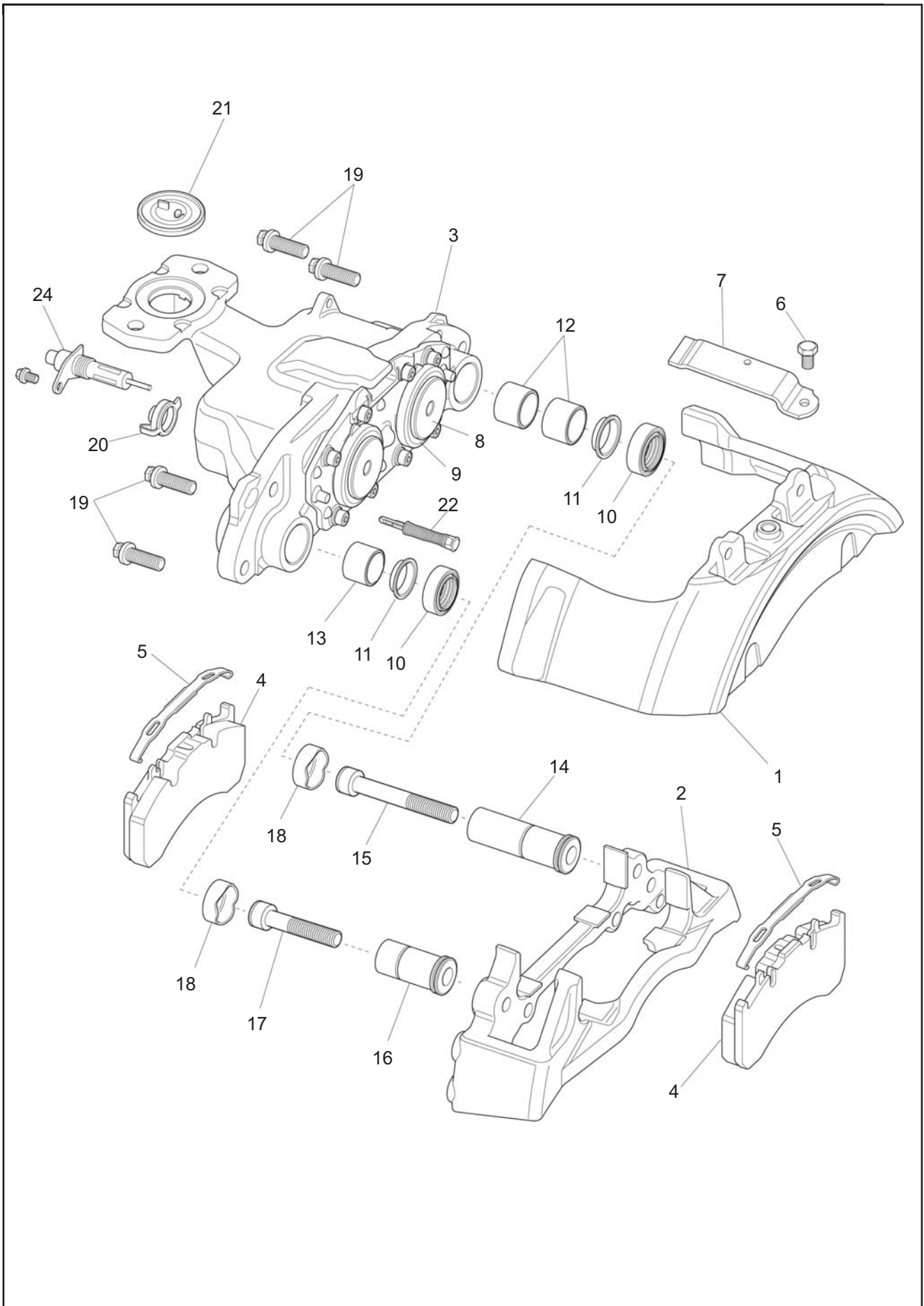

Fig 1.1b

Exploded View Parts List - Radial & Portal Brakes

Radial Brakes - Fig 1.1a

| <u>No.</u> | <u>DESCRIPTION</u> |
|------------|---|
| 1 | BRIDGE |
| 2 | CARRIER |
| 3 | HOUSING |
| 4 | PAD |
| 5 | PAD SPRING |
| 6 | SCREW (<i>Pad retaining plate</i>) |
| 7 | PAD RETAINING PLATE |
| 8 | PISTON HEAD |
| 9 | PISTON DUST EXCLUDER |
| 10 | GUIDE SLEEVE DUST EXCLUDER |
| 11 | GUIDE SLEEVE EXCLUDER RETAINER |
| 12 | GUIDE SLEEVE BUSH - ROUND |
| 13 | GUIDE SLEEVE BUSH - OVAL |
| 14 | GUIDE SLEEVES (<i>Different diameters</i>) |
| 15 | SCREW (<i>Guide sleeve</i>) |
| 18 | END CAP |
| 19 | BRIDGE SCREW X4 |
| 20 | CAP (<i>Manual adjuster stem</i>) |
| 21 | SEAL (<i>Actuator</i>) |
| 22 | VISUAL WEAR INDICATOR (<i>where applicable</i>) |

Portal Brakes - Fig 1.1b

| <u>No.</u> | <u>DESCRIPTION</u> |
|------------|--|
| 1 | BRIDGE |
| 2 | CARRIER |
| 3 | HOUSING |
| 4 | PAD |
| 5 | PAD SPRING |
| 6 | SCREW (<i>Pad retaining plate</i>) |
| 7 | PAD RETAINING PLATE |
| 8 | PISTON HEAD |
| 9 | PISTON DUST EXCLUDER |
| 10 | GUIDE SLEEVE DUST EXCLUDER |
| 11 | GUIDE SLEEVE EXCLUDER RETAINER |
| 12 | GUIDE SLEEVE BUSH - ROUND |
| 13 | GUIDE SLEEVE BUSH - OVAL |
| 14 | GUIDE SLEEVE - LONG |
| 15 | SCREW (<i>Guide sleeve long</i>) |
| 16 | GUIDE SLEEVE - SHORT |
| 17 | SCREW (<i>Guide sleeve short</i>) |
| 18 | END CAP |
| 19 | BRIDGE SCREW X4 |
| 20 | CAP (<i>Manual adjuster stem</i>) |
| 21 | SEAL (<i>Actuator</i>) |
| 22 | VISUAL WEAR INDICATOR (<i>where applicable</i>) |
| 24 | CWS (<i>Wear Sensor/Switch - where applicable</i>) |

Exploded View - Typical 225L & 225H Axial Brake Assembly

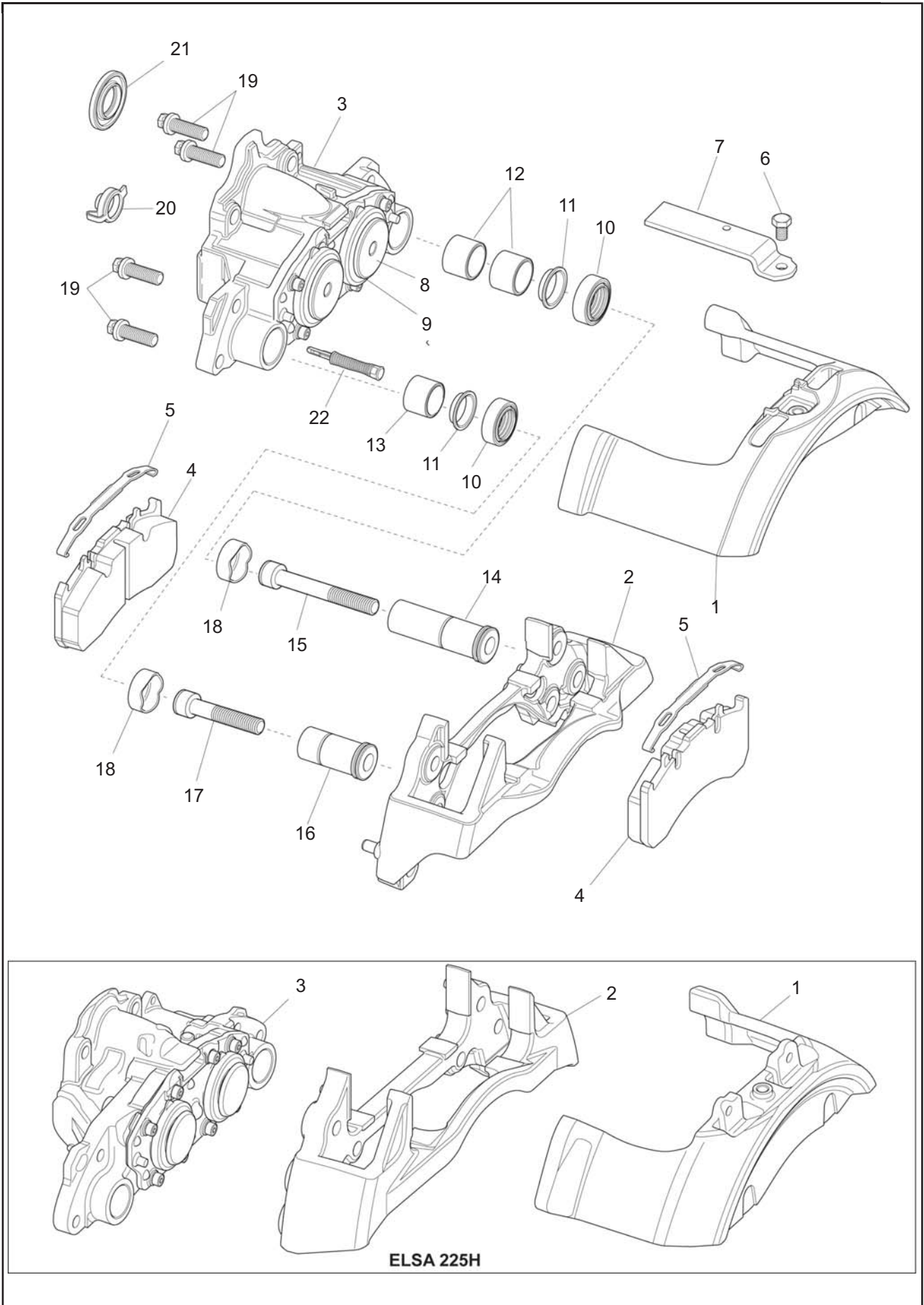

Fig 1.2b

Exploded View - Typical 225E Axial Brake Assembly

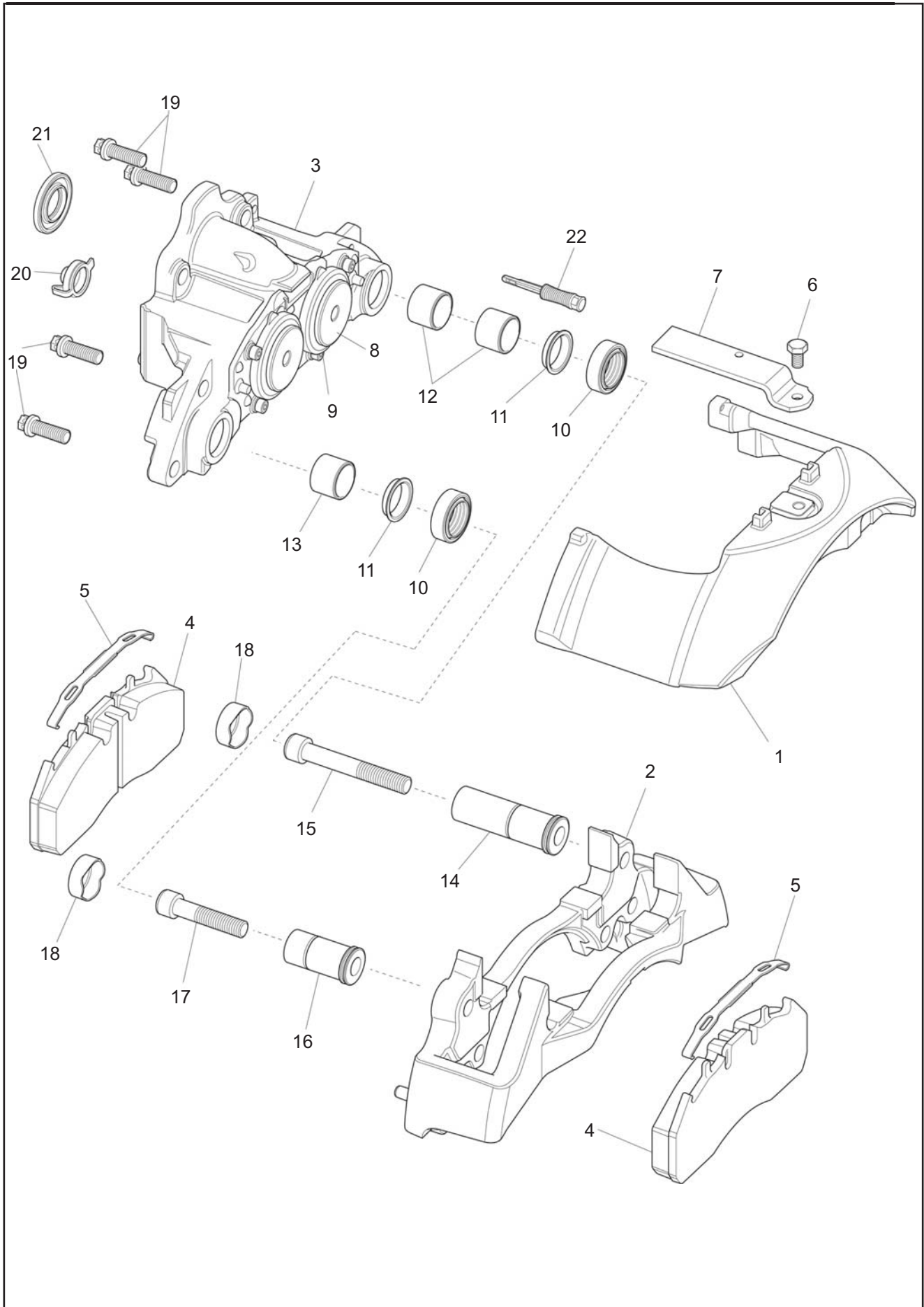

Fig 1.2c

Exploded View - Typical EX225L Axial Brake Assembly

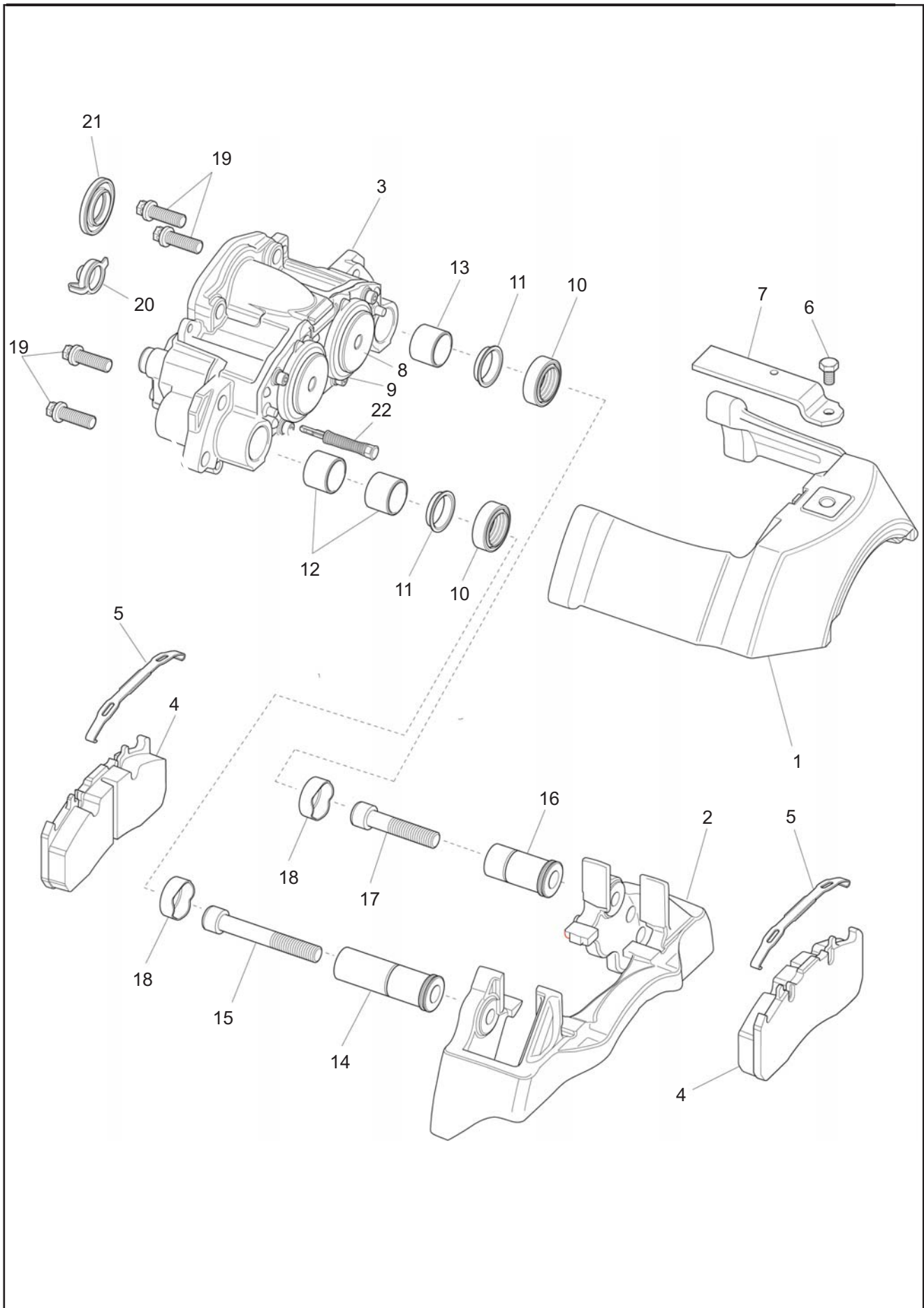

Fig 1.2d

Exploded View - Typical 250 Axial Brake Assembly (With Tangentially mounted Carrier)

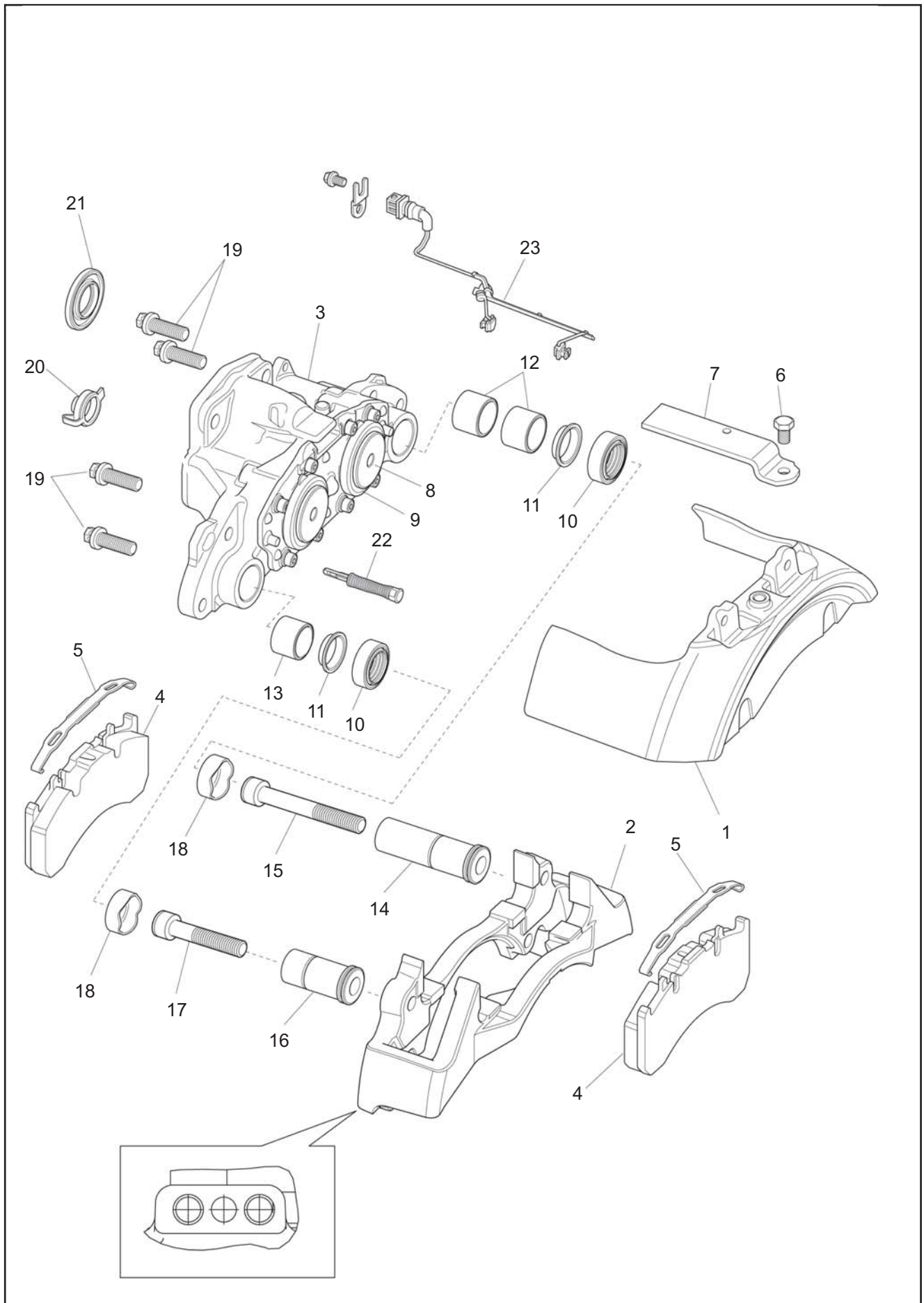

Fig 1.2e

Exploded View - Typical 225H Axial Brake Assembly

(With Axial or Tangential Carrier and Cartridge Continuous Wear Sensor)

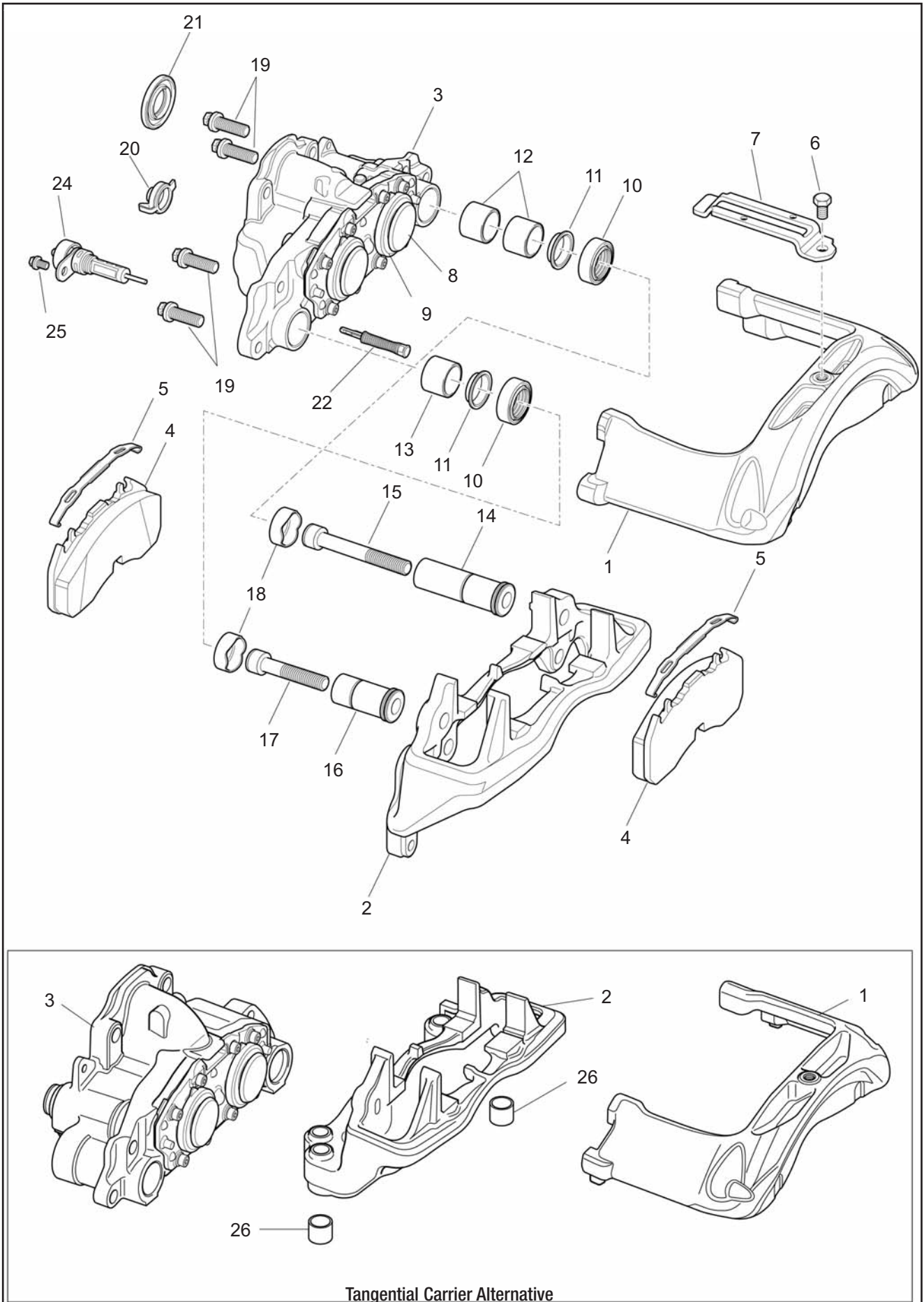

Fig 1.2f

Exploded View Parts List - Axial Brakes

| No. | DESCRIPTION |
|------------|---|
| 1 | BRIDGE |
| 2 | CARRIER |
| 3 | HOUSING |
| 4 | PAD |
| 5 | PAD SPRING |
| 6 | SCREW (<i>Pad retaining plate</i>) |
| 7 | PAD RETAINING PLATE |
| 8 | PISTON HEAD |
| 9 | PISTON DUST EXCLUDER |
| 10 | GUIDE SLEEVE DUST EXCLUDER |
| 11 | GUIDE SLEEVE EXCLUDER RETAINER |
| 12 | GUIDE SLEEVE BUSH - ROUND |
| 13 | GUIDE SLEEVE BUSH - OVAL |
| 14 | GUIDE SLEEVE - LONG |
| 15 | SCREW (<i>Guide sleeve long</i>) |
| 16 | GUIDE SLEEVE - SHORT |
| 17 | SCREW (<i>Guide sleeve short</i>) |
| 18 | END CAP |
| 19 | BRIDGE SCREW X4 |
| 20 | CAP (<i>Manual adjuster stem</i>) |
| 21 | SEAL (<i>Actuator</i>) |
| 22 | VISUAL WEAR INDICATOR (<i>where applicable</i>) |
| 23 | PWWI (<i>where applicable</i>) |
| 24 | CARTRIDGE CONTINUOUS WEAR SENSOR |
| 25 | SCREW |
| 26 | DOWEL BUSH (<i>where applicable</i>) |

Section View - (Typical Brake Assembly)

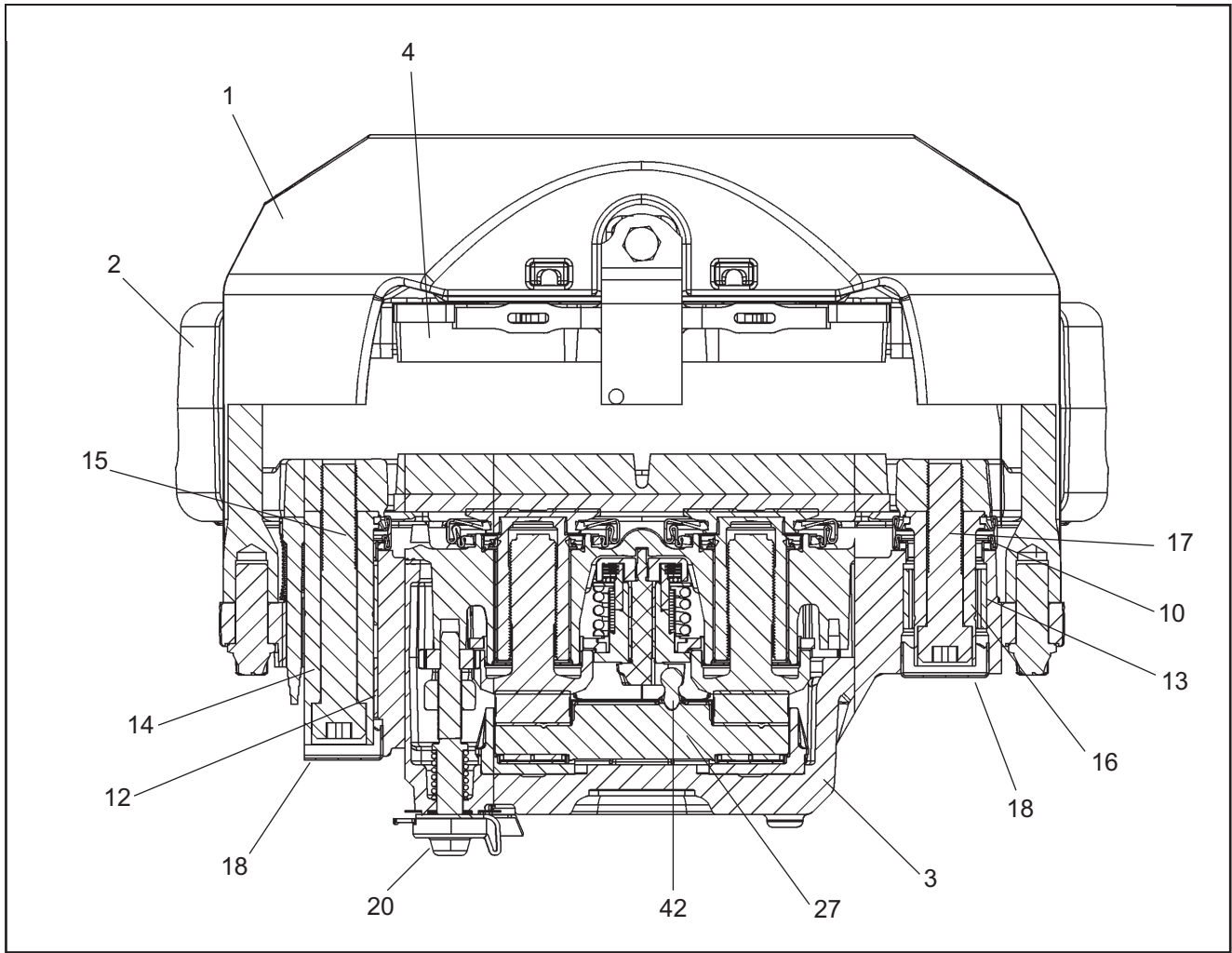

Fig 1.3

Section Views (Figs 1.3 & 1.4) - Parts List

| No. | DESCRIPTION | No. | DESCRIPTION | No. | DESCRIPTION |
|-----|-------------------------------------|-----|--|-----|--|
| 1 | BRIDGE | 20 | ADJUSTER DUST CAP | 35 | CLUTCH PLATE |
| 2 | CARRIER | 24 | CWS (<i>Wear Sensor/Switch - where applicable</i>) | 36 | INNER DRIVE SLEEVE |
| 3 | HOUSING | 25 | ROLLER | 37 | OUTER CLUTCH DRIVE SLEEVE |
| 4 | PAD | 26 | HALF BEARING | 38 | WRAP SPRING |
| 8 | PISTON HEAD | 27 | OPERATING SHAFT | 39 | PISTON HOUSING |
| 9 | PISTON DUST EXCLUDER | 28 | NEEDLE BEARING | 40 | INTERMEDIATE GEAR |
| 10 | GUIDE SLEEVE DUST EXCLUDER | 29 | SADDLE (<i>Half bearing</i>) | 41 | ADJUSTER SHAFT |
| 12 | GUIDE SLEEVE BUSH - ROUND | 30 | ADJUSTER SEAL | 42 | BALL ENDED PIN |
| 13 | GUIDE SLEEVE BUSH - OVAL | 31 | MANUAL ADJUSTER STEM | 43 | RETURN PLATE |
| 14 | GUIDE SLEEVE - LONG | 32 | TAPPET | 44 | RETURN SPRING |
| 15 | SCREW (<i>Guide sleeve long</i>) | 33 | PISTON SHAFT | 45 | WEAR SENSOR ARM (<i>Wear Sensor Shaft</i>) |
| 16 | GUIDE SLEEVE - SHORT | 34 | TRI-LOBE BUSH | | |
| 17 | SCREW (<i>Guide sleeve short</i>) | | | | |
| 18 | END CAP | | | | |

Section View - (Typical Housing Assembly)

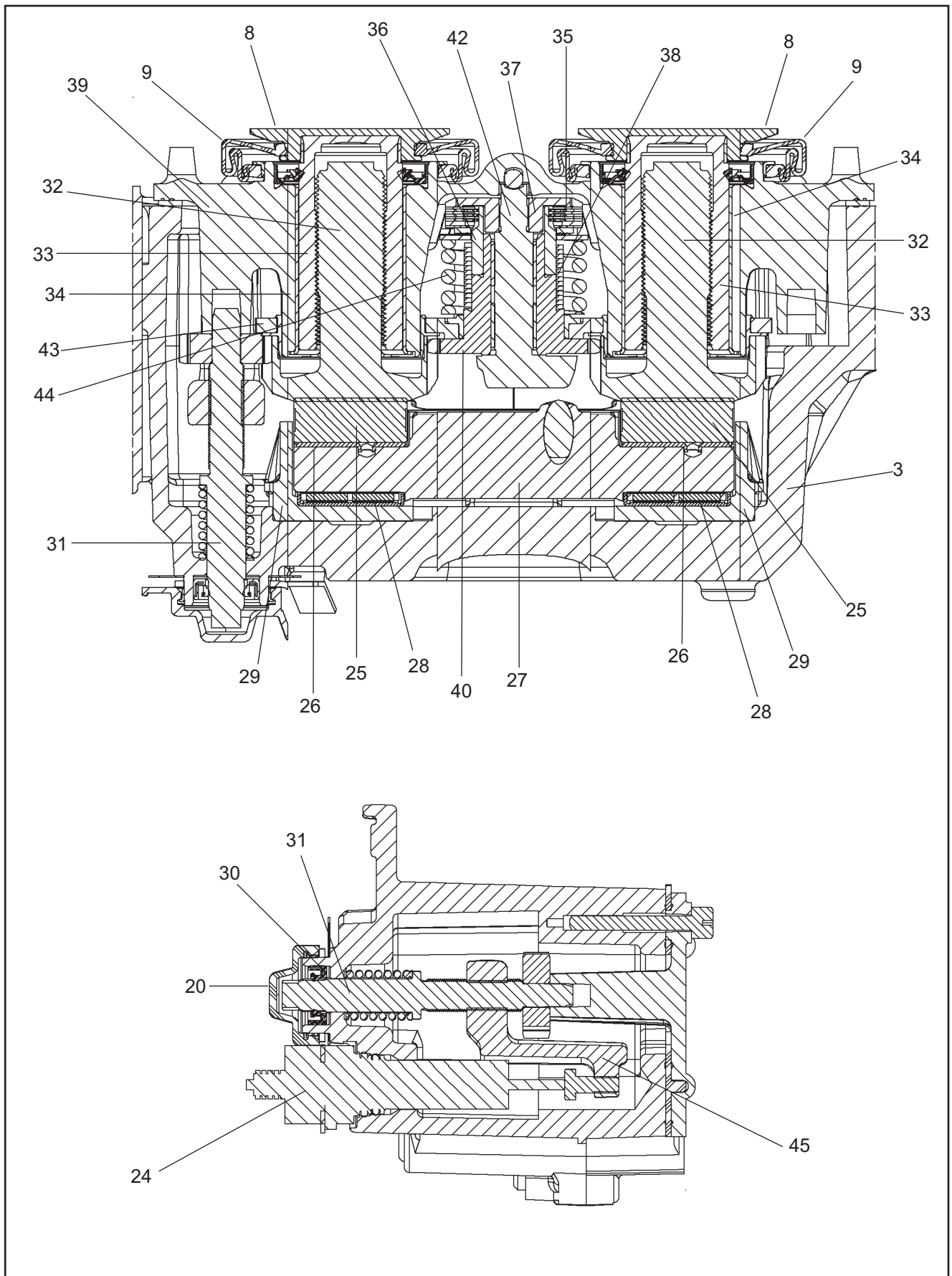

Fig 1.4

1 Introduction

NOTE: The exploded and section views contained in this manual are for reference only. The internal components are not serviceable. The screws which secure the piston housing to the brakes assembly housing **MUST NOT** be removed.

The air actuated disc brake has been designed to incorporate a direct mounted air actuator which can be mounted in a axial configuration (fig 1.5) or radial/portal configuration (fig 1.6), depending on installation requirements.

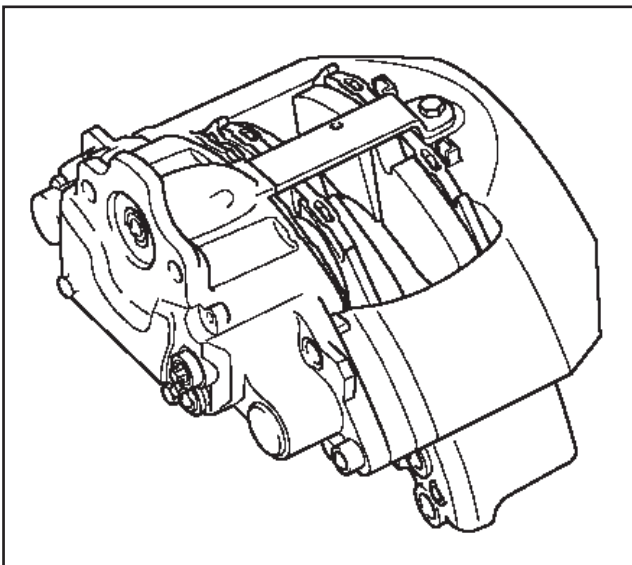

Fig 1.5

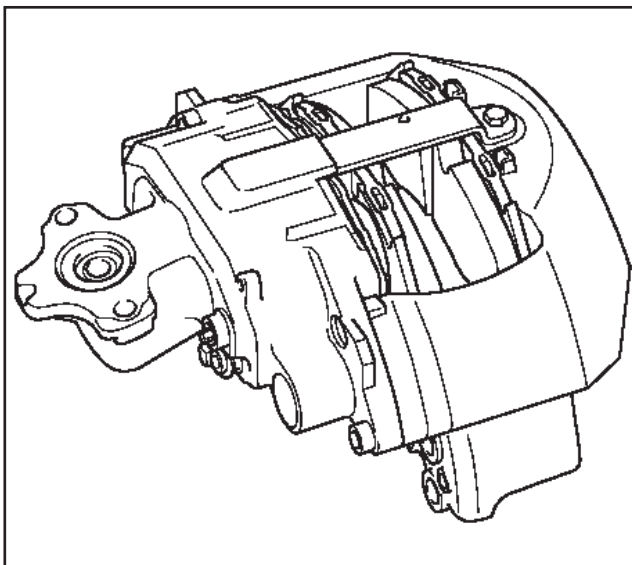

Fig 1.6

NOTE: The service procedures are common to axial, radial & portal brakes

Typical radial, portal and axial brakes are detailed in the exploded views (Figs. 1.1a, 1.1b, 1.2a, 1.2b, 1.2c, 1.2d, 1.2e & 1.2f).

The brake can be fitted to any axle and can be used for vehicle parking when a service / spring brake actuator is fitted.

The basic operation of the Brake is simple, but it is important that the features of the load insensitive automatic adjuster are clearly understood.

It is essential that the correct service procedures be observed to ensure that the Brake gives satisfactory service throughout its working life.

Brake Identification Plate

The brake identification plate is located adjacent to the manual adjuster stem cover.

How it works

(Refer to Cross Sections - Figures 1.3 & 1.4)

The air actuator is attached to the brake housing and operates directly onto the internal operating shaft assembly, thus removing the necessity for the conventional external lever and linkage arrangement.

Sealing between the air actuator and housing is achieved by seals located in the housing and actuator assembly.

The carrier, secured to the vehicle, straddles the rotor and supports the brake pads.

The housing assembly slides on two fully sealed guide sleeves bolted to the brake carrier.

As the pads wear, adjustment takes place automatically and independently of load.

NOTE: "Load Independent" means adjustment takes place under very small clamping forces only, therefore preventing over adjustment.

Two guide sleeves (14,16) are bolted on to the brake carrier (2) by means of guide sleeve screws (15,17). The brake carrier is connected to the axle. The housing (3) is mounted so that it slides on the guide sleeves. A bridge (1) is fixed to the housing (3) to provide the reaction force on the outboard pad (4). The housing and bridge slide on bushes (12 &13) that are pressed into the housing (3). On the short guide sleeve side (16), the bush (13) is oval to accommodate brake deflection during braking, whereas for the longer sleeve (14) the bushes (12) are round and provide a more positive location for the housing. The guide sleeves are sealed externally by dust excluders (10) and end caps (18).

1 Introduction

The force introduced from the air actuator is amplified by the geometry of the operating shaft (27). This clamping force is transferred to the inboard pad (4) via the half-bearings (26), the rollers (25), the tappets (32), the pistons (33) and the Piston Heads (8). Once the inboard pad (4) has been applied against the rotor, the force of reaction acting through the housing (3) and bridge (1) pulls the outboard pad (4) on to opposite side of the brake rotor. The forces created by the friction of the brake pads on the brake rotor are transferred at the ends of the pads on to the carrier (2), which is rigidly mounted to the axle.

The brakes are released by reducing the input force on the operating shaft (27), thus reducing the clamp force of the brake. The return spring (44) then returns the clamping mechanism and the operating shaft back to their starting position, leaving the pads with a defined running clearance to the rotor. The small run out of the brake rotor and hub-bearing clearances will then generate a small clearance for the outboard pad (4) through only a few revolutions of the rotor.

Some applications incorporate an Electronic Continuous Wear Sensor (24) which constantly monitors the distance across the pads and the rotor, allowing the system to monitor and adjust brake balance as pad wear across the axle is recorded.

The wear sensor (24) is driven by an arm (45) that runs up and down a fine thread on the manual adjuster stem (31).

The arm cannot rotate within the housing (3) and as adjustment of the brake mechanism occurs, the manual adjuster stem (31) rotates and the arm travels along the length of the shaft, driving the sensor.

NOTE: There are alternative design continuous wear sensors in service. When removal/replacement is necessary refer to Section 5 for the standard sensor which incorporates an integral wiring lead, and refer to Supplement 2 for the cartridge design sensor.

Automatic adjustment

The automatic adjuster makes an adjustment to the operation of the brake pad to compensate for pad wear. Every time the brake is applied, the system senses whether adjustment is required or whether the running clearance of the brake pads to the brake rotor is still within the built-in tolerance and does not need to be adjusted.

The built in tolerance is determined in the design by the clearance between the ball-ended drive pin (42) that is rigidly fixed to the operating shaft and the fork on the end of the adjuster shaft (41).

a) Operation without adjustment

From the rest position, the push rod of the air cylinder moves forward, rotating the operating shaft (27). Just as the pistons (33) have moved forward by the inbuilt running clearance, the ball ended drive pin (42) starts to contact the driving side of the fork on the end of the adjuster shaft (41). Further movement of the air actuator push rod rotates the operating shaft (27), now causing the adjuster shaft (41) to rotate because the inbuilt clearance has been taken up. The outer drive sleeve (37) is fixed to the adjuster shaft (41) and rotates the inner drive sleeve (36) via the clutch pack (35). The inner drive sleeve (36) is linked to the intermediate gear (40) by a unidirectional friction spring (38) and this tries to rotate the tappets (32). However, the friction in the threads of the tappets (32) and pistons (33) has started to increase due to the clamping force on the pads and this prevents the pistons and tappets rotating relative to one another. The pistons cannot rotate in the housing (39) and due to the high torque to turn the tappets (32) the clutch pack (35) 'slips', preventing adjustment of the mechanism below the correct running clearance.

b) Operation with adjustment

As a result of pad or rotor wear, the running clearance is now greater than the inbuilt tolerance and adjustment of the mechanism is now required. From the rest position, the push rod of the air cylinder moves forward, rotating the operating shaft (27). Just as the pistons (33) have moved forward by the inbuilt running clearance, the ball-ended drive pin (42) starts to contact the driving side of the fork on the end of the adjuster shaft (41). Further movement of the operating shaft, now causes rotation of the adjuster shaft (41) via the ball-ended drive pin (42). Driving through the clutch plates (35) and the unidirectional friction spring (38), the intermediate gear (40) rotates. Due to the excessive running clearance the intermediate gear teeth rotate the tappets in the pistons.

The pistons (33) cannot rotate and are, therefore, wound out from their housing (39). When the pistons push the piston heads onto the pads, the pads contact the rotor, the clamping force increases the thread friction in the tappets (32) and pistons (33). The torque to turn the tappets (32) then increases and the clutch pack (35) driving the intermediate gear (40) starts to slip, preventing further adjustment. The adjustment is not wound back during the return of the actuation mechanism due to the designed slip in the unidirectional friction spring.

1 Introduction

As the operating shaft (27) now returns to the brakes off position, the ball-ended drive pin (42) travels back through the clearance in the fork on the end of the adjuster shaft (41). Once this clearance is taken up, the adjuster shaft (41) then rotates in the reverse direction, rotating the inner drive sleeve (36) via the clutch pack (35). However, in this direction, the unidirectional friction spring (38) cannot drive the intermediate gear (40), leaving the tappets (32) and intermediate gear (40) in the adjusted state. The system is now once again in its starting position.

c) Manual adjustment and de-adjustment during a pad change

Manual adjustment of the brake must only be made at a pad change. No manual intervention is required between pad changes.



CAUTION:

Before any de-adjustment is made it is important to check the condition of the piston dust excluders. If damage to the dust excluders is evident the piston must be thoroughly cleaned. Failure to do this could result in damage to the secondary piston seals.

A manual adjuster stem (31) runs in constant mesh with the gear form on the outside of the tappets (32). The end of this stem comes out from the brake housing through a seal (30) and is protected further by an adjuster cap (20). To increase the gap between the Piston Heads (8) and the bridge (1) in order to fit new pads, remove the adjuster cap (20) and rotate the shaft (31) in an anti-clockwise direction.

After fitting new pads an initial running clearance needs to be set and some manual adjustment may be required. To reduce the gap between the Piston Heads (8) and the bridge (1), remove the adjuster cap (20), locate a 10mm socket on the adjuster stem (31) and turn it clockwise viewed from the air actuator side.

NOTE: Ensure, if fitted, the electrical wear sensor cable is not damaged when using the manual adjust/de-adjust stem (Fig 1.7).

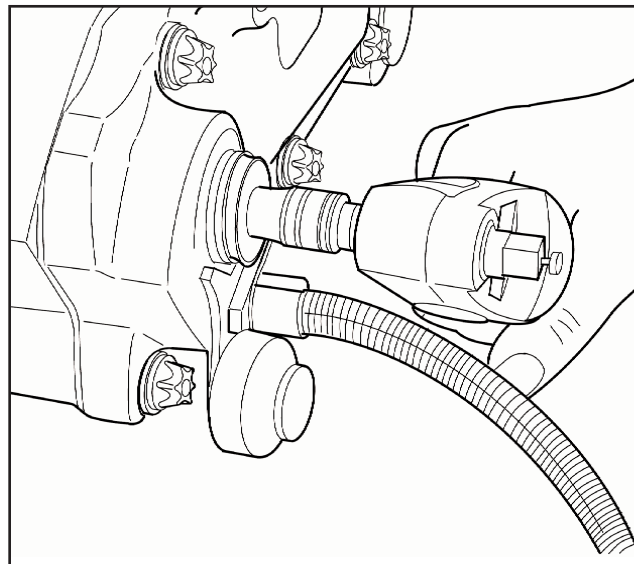

Fig 1.7

Continue to adjust the brake until the pads lightly grip the rotor. De-adjust the brake by $\frac{1}{2}$ a turn of the wrench, this will give a nominal 1mm pad to rotor clearance. Ensure the rotor is free to turn. Replace the adjuster cap (20).



WARNING:

Always de-adjust/adjust the brake carefully by hand with a suitable wrench. Never exceed a maximum torque of 40 Nm in either direction and NEVER use power tools.

1 Introduction

Actuator

The ELSA 195/225/250 disc brake uses a 65 mm stroke actuator, (Fig. 1.8).

This actuator is supplied with a pushrod setting length of 15 mm.

It is important the correct actuator is fitted, fitting an actuator with a longer stroke, 76mm, is accompanied by a push rod length of 20 mm.



CAUTION:

If an incorrect brake actuator is fitted, difference in push rodlength will result in partial application of the brake when the actuator is bolted to the housing, this may lead to the brake dragging.

The actuator can be identified by part number on the actuator nameplate.

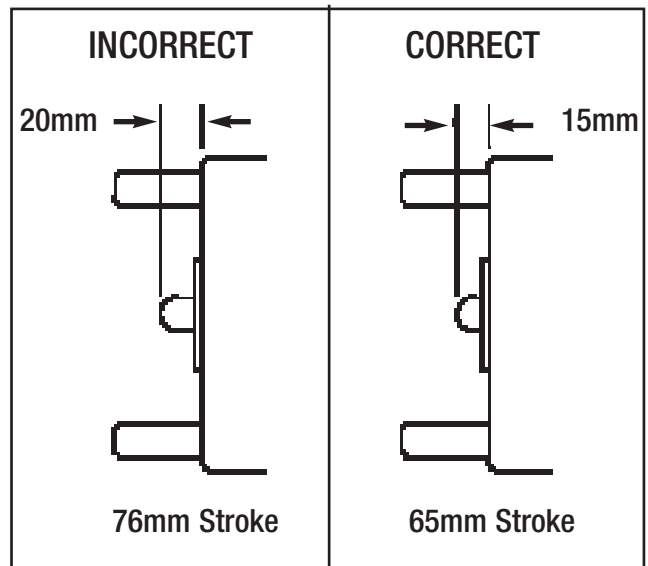

Fig 1.8

1 Introduction

Operational Checks

2

- pg. 26 Automatic adjuster test
- pg. 28 Sliding action Check
- pg. 28 Slide pin wear check
- pg. 31 Pad wear
- pg. 33 Rotor checks

2 Operational Checks

Automatic Adjuster Function Test

This operation can usually be carried out with the wheels on over an inspection pit or with the vehicle lifted.

Where the vehicle is standing on its wheels chock the wheels securely and release the parking brake.

If it is necessary to remove the wheels ;

Park the vehicle on hard ground and chock the road wheels.

Apply air pressure and fully charge the system to ensure the park brake is fully released (where appropriate). Jack up the axle and fit suitable axle stands securely. Remove the road wheels

Procedure

Remove the dust cap on the adjuster stem

(Fig. 2.1).

Set an increased pad to rotor clearance by de-adjusting the brake one turn of the adjuster stem, or, with the wheels removed, a measured gap of approximately 2-3 mm between the pad and the rotor.

To de-adjust the brake locate a suitable 10 mm socket wrench on the adjuster stem and rotate the wrench in an anticlockwise direction as viewed from the air chamber side.(Fig. 2.2)

⚠ CAUTION: If the wrench stops rotating while de-adjusting turn the wrench in the opposite direction ¼ turn

⚠ WARNING:

Always de-adjust/adjust the brake carefully by hand with a suitable wrench. Never exceed a maximum torque of 40 Nm in either direction and NEVER use power tools.

As an adjuster function indicator; position a 10 mm ring wrench on the adjuster stem, (Fig. 2.3) to allow at least ¼ turn of free movement in the clockwise direction viewed from the air chamber side.

⚠ CAUTION: While operating the brake, DO NOT hold the wrench.

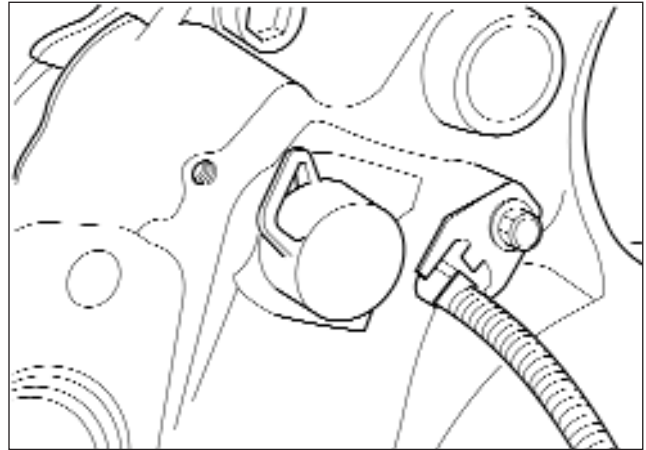

Fig. 2.1

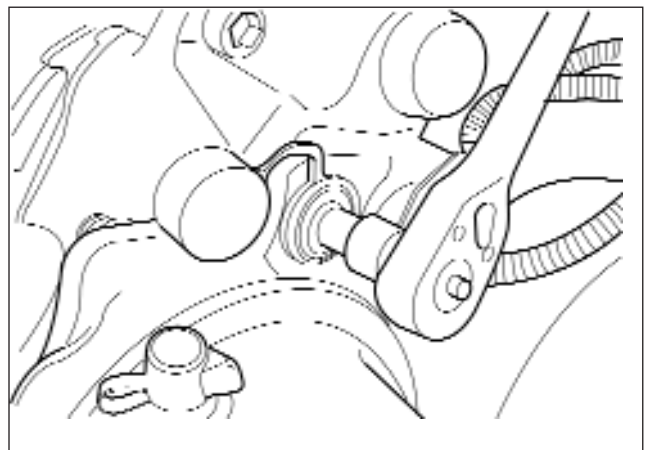

Fig. 2.2

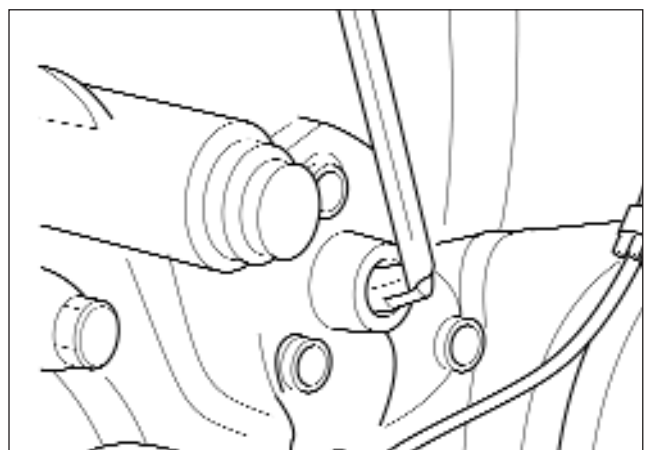

Fig. 2.3

2 Operational Checks

Operate the service brake several times with approximately 1 to 2 bar air pressure.

Observe the direction of rotation of the ring wrench. This should be in a clockwise direction viewed from the air chamber side as shown in Fig 2.4 or 2.5

NOTE: As the number of brake applications increase, the movement of the ring wrench will become smaller.

Possible faults:

- Ring wrench does not turn
- Ring wrench turns backwards and forwards.

If any of the above faults arise, the housing assembly must be replaced, see **Housing replacement - Section 8**.

After a successful check set the running clearance between the brake rotor and pad. To do this, turn the adjuster stem in the clockwise direction viewed from the air chamber side until an increase in resistance is felt and both pads touch the rotor. Then turn the adjuster back $\frac{1}{2}$ a turn, thus creating a running clearance.

Refit the dust cap on the adjuster stem

Charge the air system and apply the brakes 5 times to settle the pads and allow the auto adjuster to set the correct running clearance.

Where the road wheels have been removed to carry out the adjuster test, check that the rotor is free to rotate.

Where applicable, refit the wheels and tighten the nuts to the vehicle manufacturer's torque specification. Jack the vehicle down to the ground.

Road test.

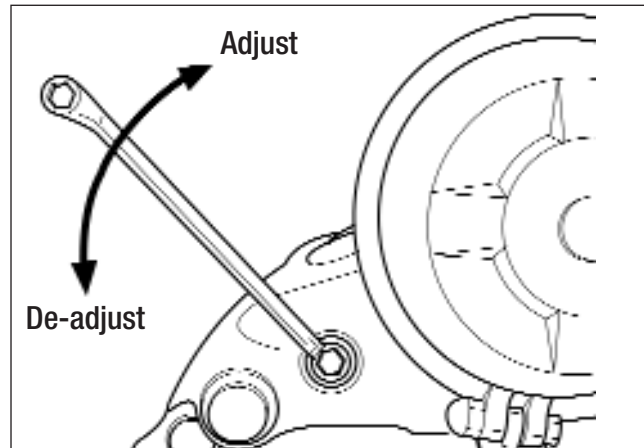

Fig. 2.4

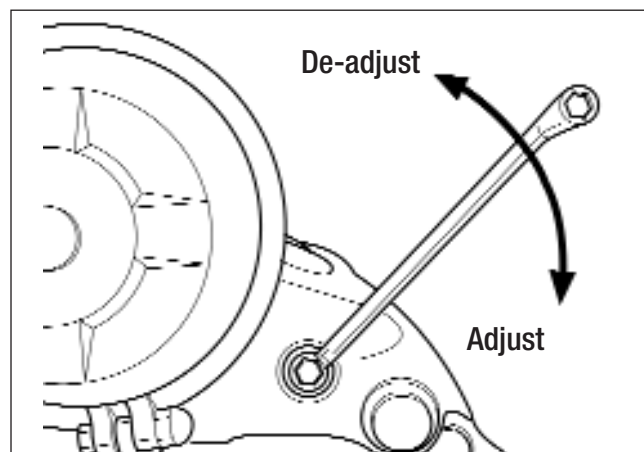

Fig. 2.5

2 Operational Checks

Checking the Sliding action of the housing

Park the vehicle on hard ground and chock the road wheels. Apply air pressure to release the park brake and wind off the spring brake retraction bolt (where appropriate). Jack up the axle and fit suitable axle stands securely. Remove the road wheels and exhaust all air from the system.

Remove pads as described in **Pad replacement - Section 3**

Move the housing backwards and forwards in the direction of the arrow, as shown in Fig. 2.6. It must be possible to push/pull the housing easily by hand.

NOTE: Be careful not to damage the guide sleeve excluders when sliding the housing.



CAUTION: Take care not to trap fingers whilst sliding the brake.

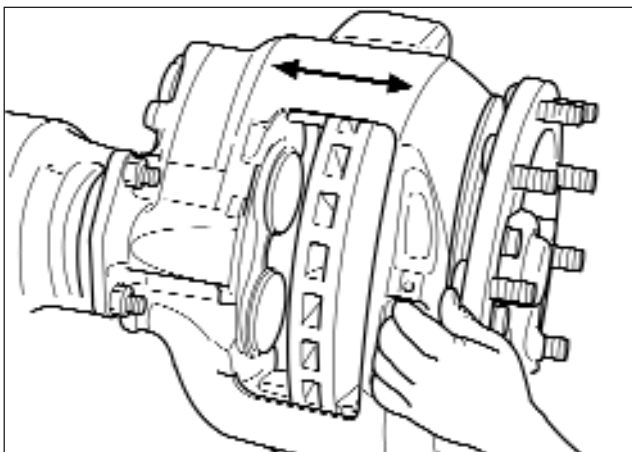

Fig. 2.6

Checking Slide Pin Bush Wear

Radial Test

Remove the pads as described in **Pad replacement - Section 3**.

Fit the Meritor CVA. service tool MST 1017 (Fig. 2.7) to the pad retaining plate screw hole in the correct position (Fig. 2.8). The slot in the tool must be parallel to the rotor.

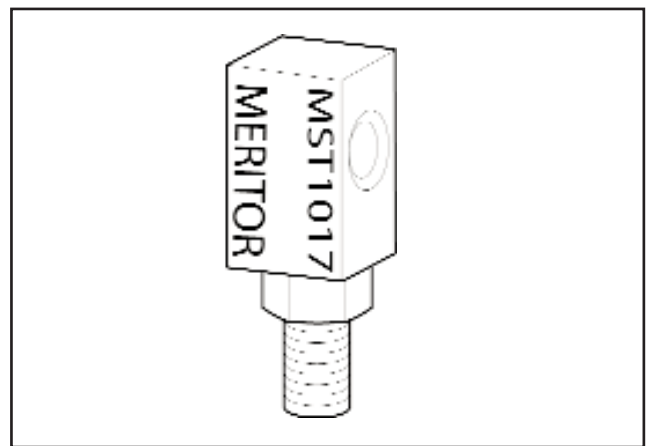

Fig 2.7

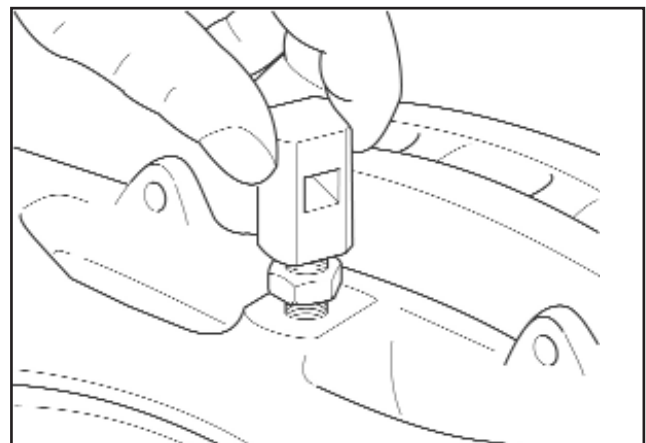

Fig 2.8

2 Operational Checks

Lock the tool in position with the locknut as shown in Fig 2.9.

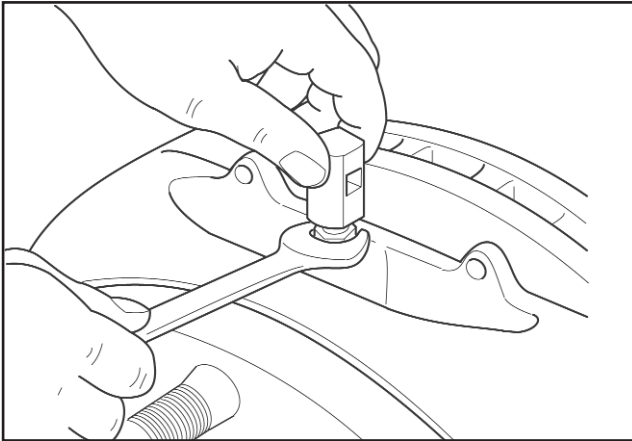

Fig 2.9

Position the brake in the new pad condition. This is achieved by sliding the brake housing fully in the direction of arrow A (Fig. 2.10) (Towards the wheel hub)



CAUTION: Take care not to trap fingers whilst sliding the brake.

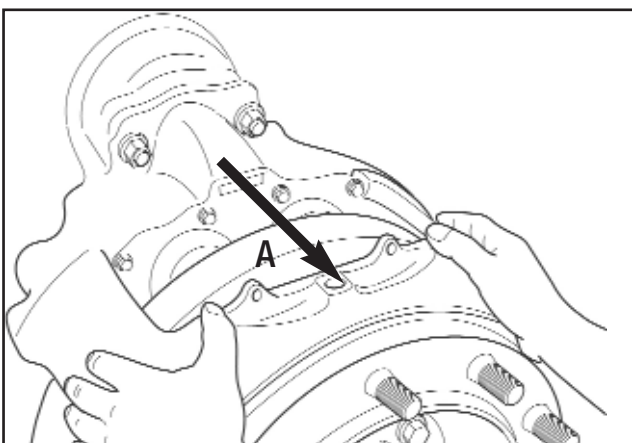

Fig 2.10

Mount a dial gauge in a suitable position on the vehicle hub and set against the service tool as shown in Fig. 2.11. Ensure the hub cannot rotate

Set the dial gauge to zero.

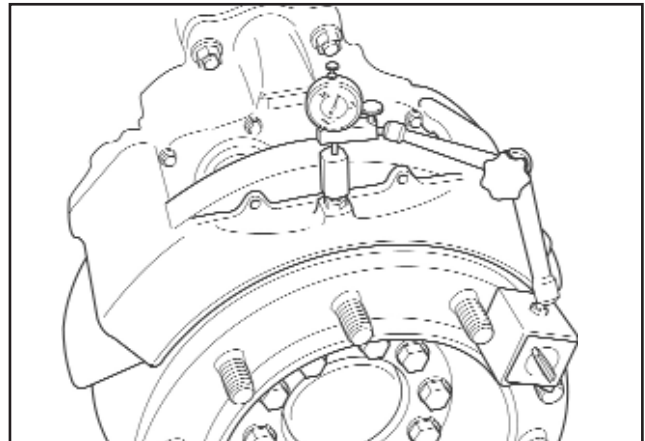

Fig 2.11

Fit a torque wrench to the tool in the position as shown in Fig. 2.12.

Apply the torque wrench in the correct direction (Fig 2.12) to 25Nm without allowing the brake to slide and note the dial gauge reading.

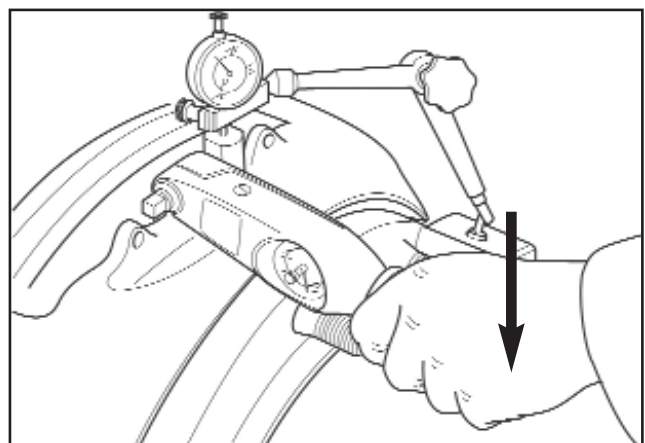

Fig 2.12

2 Operational Checks

Remove the torque wrench and fit to the opposite side socket in the service tool (Fig. 2.13).

NOTE: DO NOT RESET THE DIAL GAUGE.

Apply the torque wrench in the correct direction (Fig 2.13) to 25Nm without allowing the brake to slide and note the dial gauge reading.

NOTE: Take care not to disturb the position of the dial gauge when applying the torque wrench.

Add the two dial gauge readings together to give total free play measurement.

NOTE: Max acceptable free play measurement is 2.0mm

If this figure is exceeded the guide sleeve pins and bushes require attention.

Using the correct service kits overhaul the slide pins following the procedure detailed in **Guide sleeve replacement - section 11**.

Remove the service tool MST 1017

Replace the pads and if applicable PWWI, set the running clearance and test as described in **Pad replacement - section 3**.

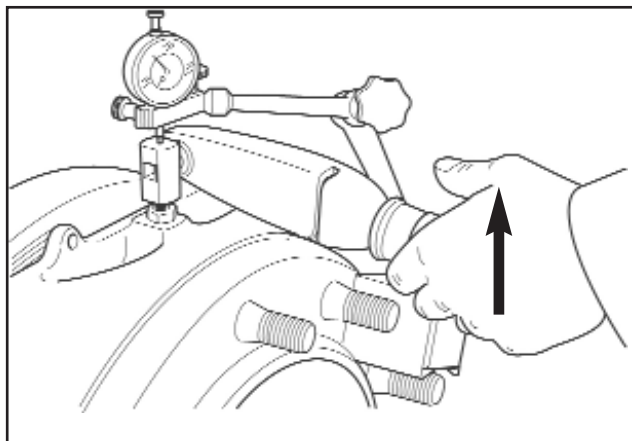

Fig 2.13

2 Operational Checks

Pad Wear Check

NOTE: Brake pad should be replaced when the lining thickness has worn to 3.0 mm.

The ELSA 195/225/250 Air Disc Brake can incorporate a variety of devices to monitor pad wear as detailed below.

PWWI (Pad Wear Warning Indicator)

Pad Wear Warning Indicators are fitted to the pad/s (Fig 2.14 shows a typical arrangement) and will illuminate a warning lamp on the vehicle instrument panel to indicate that a pad change is required.

CWS (Continuous Wear Sensor or Switch)

The continuous wear sensor (Fig 2.15a) or switch (Fig 2.15b) fitted within the brake constantly monitor the distance across the pads and the rotor and will illuminate a warning lamp on the vehicle instrument panel to indicate that a pad change is required.

Visual Wear Indicator

There are alternative visual wear indicator arrangements in service, Type A (Indicator stem and spring) and Type B (cast features on the bridge and carrier)

Where a visual pad wear indicator is incorporated into the brake it provides a quick and simple method of assessing the pad life remaining.

Type A (Indicator Stem and Spring)

(In a new pad condition the end of the indicator stem will extend past the edge of the housing casting (Fig 2.16). As the pads wear the length of indicator visible past the edge of the casting will reduce. The indicator is incremented with each increment equating to a level of pad wear (Fig 2.17).



CAUTION: Before using the visual wear indicator to assess pad lining wear, and to achieve an accurate indication of lining wear it is important to check that the visual wear indicator is not seized in the housing. To do this pull and rotate the end of the wear indicator, by hand against the spring pressure, If the indicator will not move freely and return to its original position under spring pressure, refer to Section 8 Housing & Visual Wear Indicator Replacement.

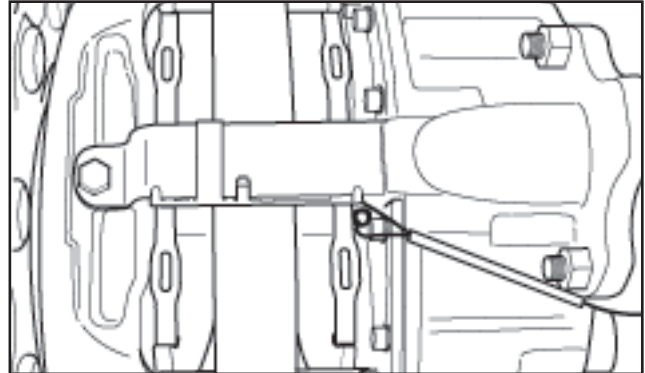

Fig 2.14

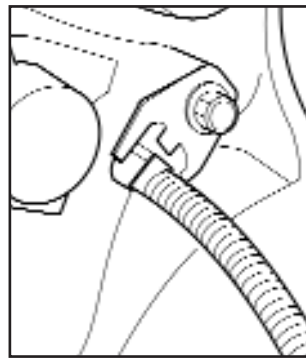

Fig 2.15a

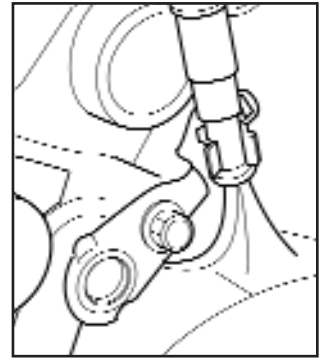

Fig 2.15b

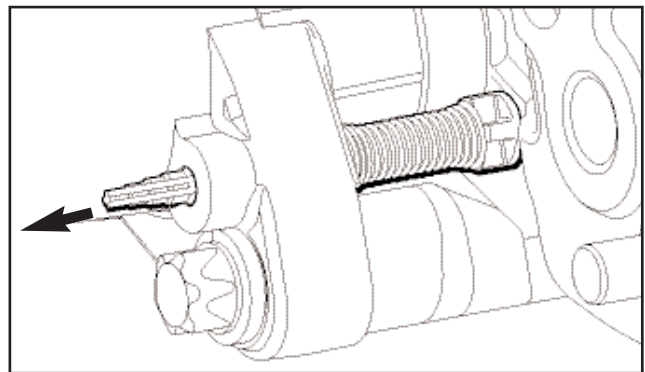

Fig 2.16

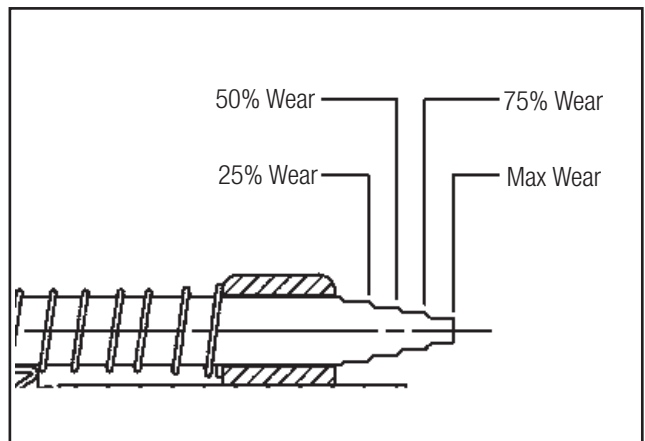

Fig 2.17

2 Operational Checks

Type B (Cast Feature on Bridge and Carrier)

Certain applications incorporate a cast feature on the bridge and carrier (Fig. 2.18) which by observing the alignment of the cast features will indicate pad wear.

Fig. 2.19 shows the position of the cast features in a new pad condition.

Fig. 2.20 shows the cast features in a fully worn pad condition.

 **CAUTION:** Ensure any discarded friction product, or cloth contaminated with brake dust, is disposed of in accordance with local environmental regulations.

 **CAUTION:** You must always renew the brake pads on both wheels of an axle. Only use the brake pads that have been approved by the vehicle manufacturer.

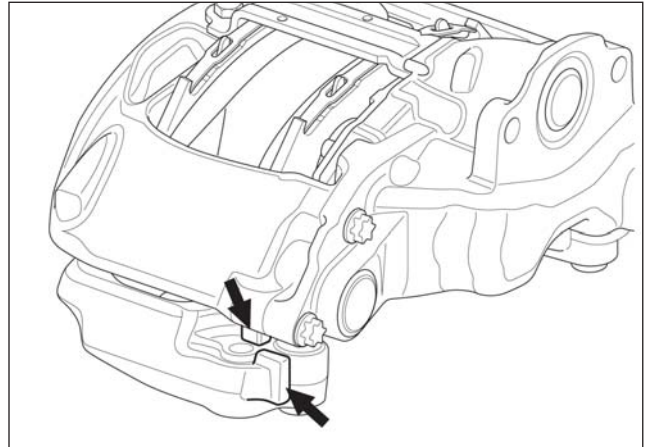

Fig 2.18

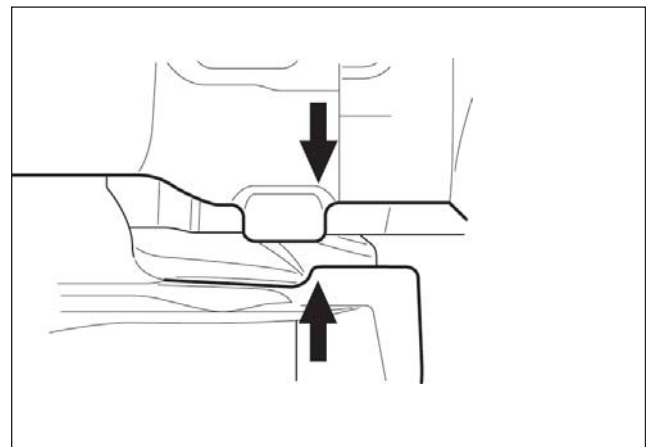

Fig 2.19

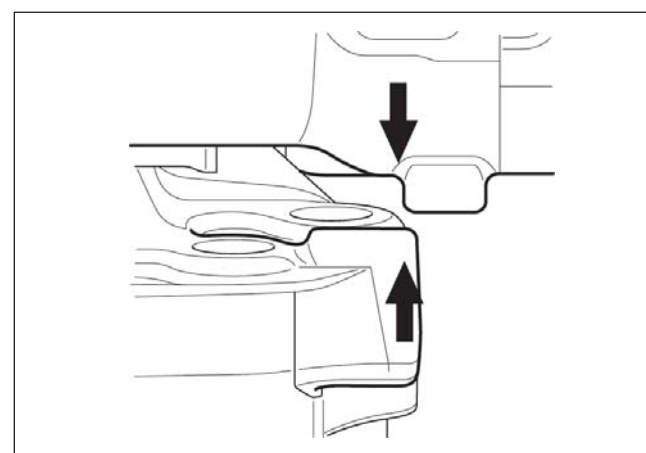

Fig 2.20

2 Operational Checks

Rotor Inspection and Maintenance

Check the rotor for grooves, cracks, heat crazing, scoring and bluing.

Whilst wearing suitable eye protection remove scale, dirt and corrosion etc from around the edge of the rotor. Use an emery cloth if necessary.

NOTE: One way to remove corrosion is to support a screwdriver or scraper on the brake body and rotate the rotor by hand.

Rotor

Check that the rotor's thickness dimension meets the manufacturer's specification and those detailed in the **Rotor re-work & replacement - section 13**. If there is any doubt in the serviceability of the rotor refer to the vehicle manufacturer for corrective action.

NOTE: If the rotor's thickness dimension is not high enough to permit expected wear before the next brake pad change: Replace the rotor.



CAUTION: You must always renew the rotor on both wheels of an axle. Only use the rotors that have been approved by the vehicle manufacturer.

Inspect both rotor surfaces for the following conditions.

Cracks (Fig 2.21)

Cracks that extend through to the vent of a ventilated rotor or 25% through the thickness at the outer edge of a solid rotor: Replace the rotor.

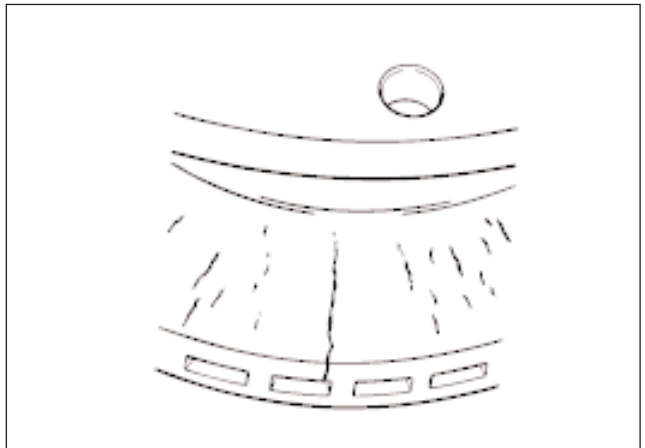

Fig 2.21

Heat Crazing (Fig 22)

Heat crazing is fine cracks on the rotor's surface.

This is a normal condition that results from continuous heating and cooling of the friction surface.

Braking under normal operating conditions can cause cracks to separate and deepen, increasing lining wear.

There are two types of heat crazing: light and heavy.

Light Heat Crazing (Fig 2.23)

Light heat crazing is fine, tight cracks in the rotor's surface.

Continue to use a rotor with light heat crazing.

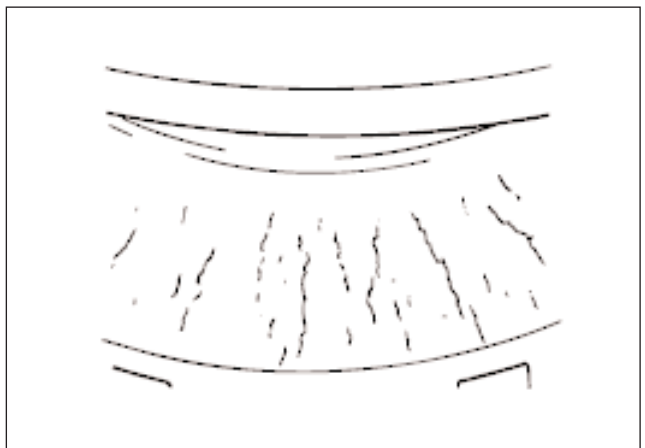

Fig 2.23

2 Operational Checks

Heavy Heat Cracking (Fig 2.24)

Heavy heat cracking is cracks in the rotor's surface that extend radially and have an individual length of up to 75% brake path width.

Refinish or replace a rotor that has heavy heat cracking.

NOTE: Surface finish after machining should be 5-Ra microns maximum.

NOTE: Localised crazing / blue patches / cracking in only one part of the rotor could be caused by rotor run-out or thickness variation. Refer to vehicle manufacturer for tolerances.

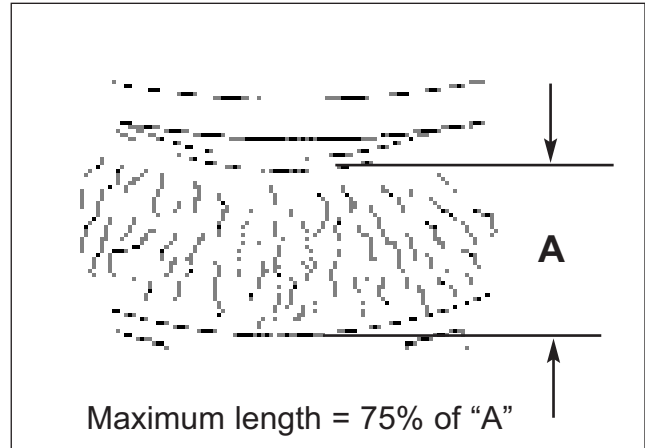

Fig 2.24

Scoring (Fig 2.25)

Scoring is deep circumferential grooves that can occur on both sides of the rotor's surface. If the groove or multiple scores are of a depth less than 0.5 mm, continue to use the rotor. If the groove / scores are greater than 0.5 mm, refinishing the rotor is recommended.

Refinishing the rotor is recommended before fitting new brake pads.

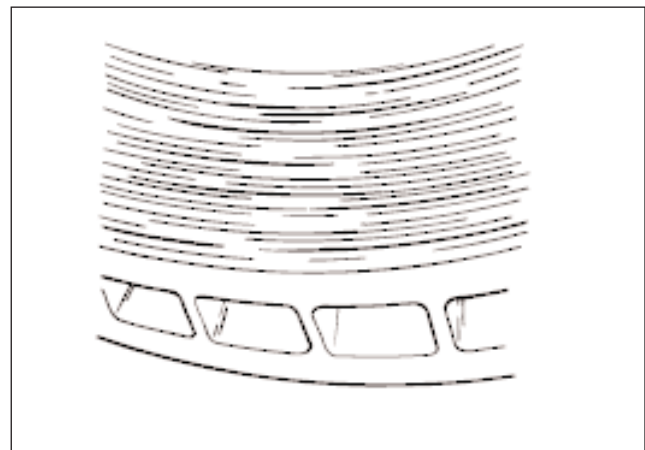

Fig 2.25

"Blue" Rotor (Fig 2.26)

Blue marks or bands on the rotor indicate that extremely high temperatures occurred during operation. Refinishing the rotor is recommended before fitting new brake pads.



CAUTION: Reasons for the excessively high temperatures must be investigated as this will adversely affect brake performance and lining wear rate. Continued operation at excessively high temperatures will eventually adversely affect brake function.

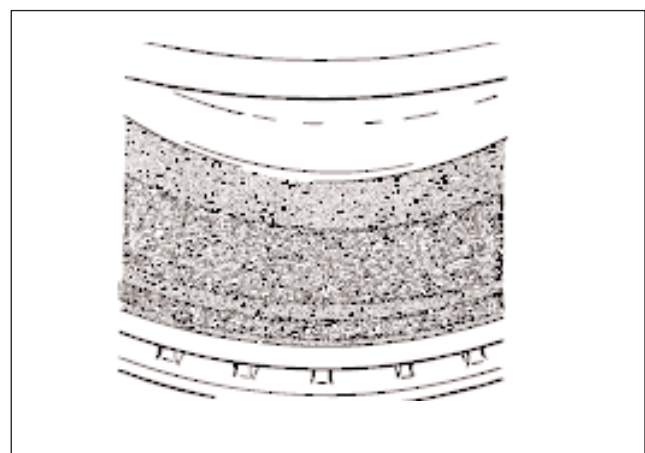

Fig 2.26

Pad Replacement

3

- pg. 36 Pad retaining plate removal (with PWVI fitted)
- pg. 38 Pad removal
- pg. 38 Cleaning and Inspection
- pg. 39 Fitting new pads

3 Pad Replacement



CAUTION: You must always renew the brake pads on both wheels of an axle. Only use the brake pads that have been approved by the vehicle manufacturer. Brake pads must be replaced when the lining thickness has worn to 3mm minimum.

Park the vehicle on hard ground and chock the road wheels. Apply air pressure and fully charge the system to ensure the park brake is fully released. Wind off the spring brake retraction screw (where appropriate). Jack up the axle and fit suitable axle stands securely. Remove the road wheels and exhaust all air from the system. Remove any dirt from the Brake assembly. Ensure the rubber dust excluders fitted to the Piston Heads and guide sleeves are not damaged.



CAUTION: Never use an airline to blow dust from the brake/rotor area. If inhaled any form of dust can at best be an irritant, at worst dangerous. Whenever possible remove dry brake dust with a vacuum brush. Alternatively wipe the areas with a damp cloth, never try to accelerate drying time by using an airline.



CAUTION: Ensure any discarded friction product, or cloth contaminated with brake dust, is disposed of in accordance with local environmental regulations.

Pad Retaining Plate Removal (with PWWI if fitted)

The Elsa 195/225/250 Air Disc Brake can incorporate alternative PWWI arrangements to monitor pad wear, Type A, Type B and Type C. The different PWWI arrangements available are shown in Fig 3.1a, Fig 3.1b & Fig 3.1c.

Before removing any components note the type of PWWI arrangement fitted to the brake assembly.

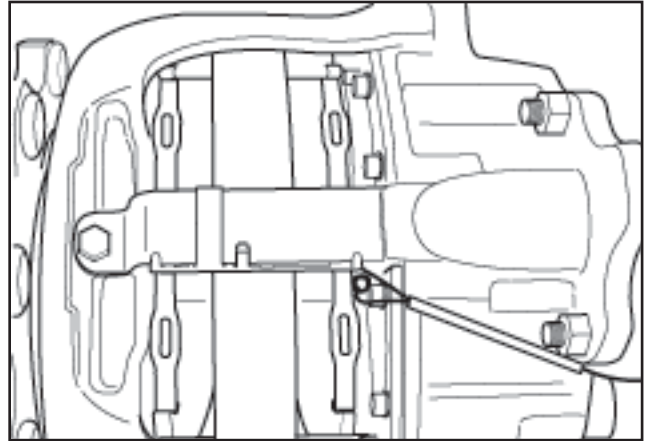

Fig 3.1a

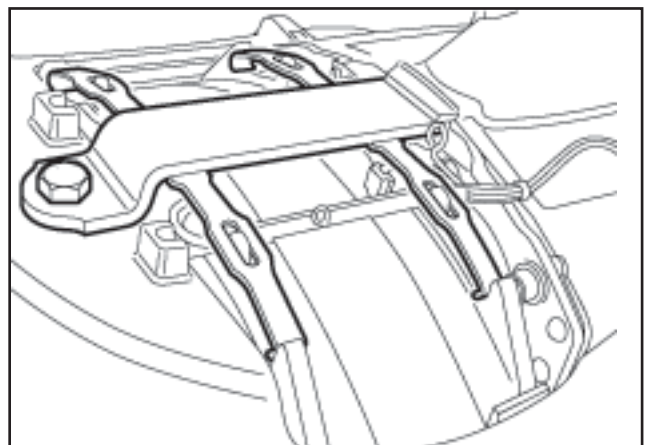

Fig 3.1b

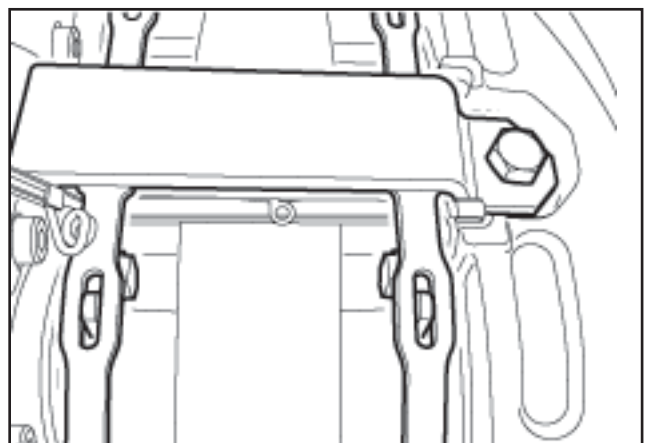

Fig 3.1c

3 Pad Replacement

Type A

Remove the pad retaining plate screw and discard (Fig 3.2). Remove the pad retaining plate from the slot in the housing casting but do not attempt to remove it further at this stage. Remove the pad springs.

If re-using the PWWI, carefully remove both plastic sensor blocks from their location in the pads (Fig 3.3). Do not use excessive force as this may result in damage.

It is now possible to remove the pad retaining plate and PWWI assembly as far as the connecting cable will allow. Ensure that this cable is not stretched.

If a new PWWI is to be fitted, note the position/layout of the pad wear cable. Carefully unclip the pad wear warning cable retainer from the pad retaining plate.

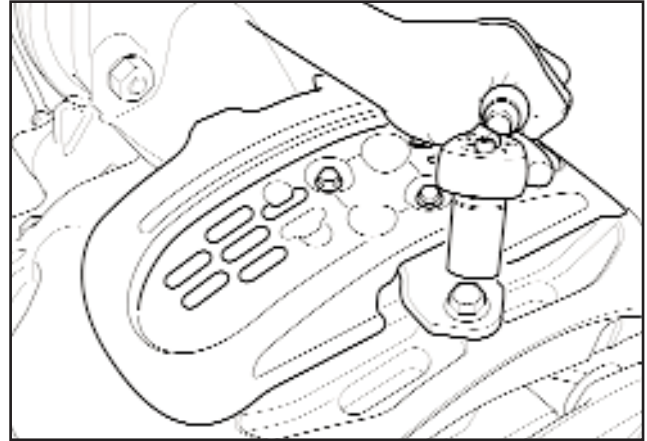

Fig 3.2

Types B & Type C

Remove the pad retaining plate screw (Fig 3.2).

Remove the pad retaining plate from the slot in the housing casting and remove from the brake. Remove the pad springs. Lift out the PWWI assembly, disengaging the tang from the housing (Fig 3.4)

If re-using the PWWI, carefully remove both plastic sensor blocks from their location in the pads (Fig 3.3). Do not use excessive force as this may result in damage.

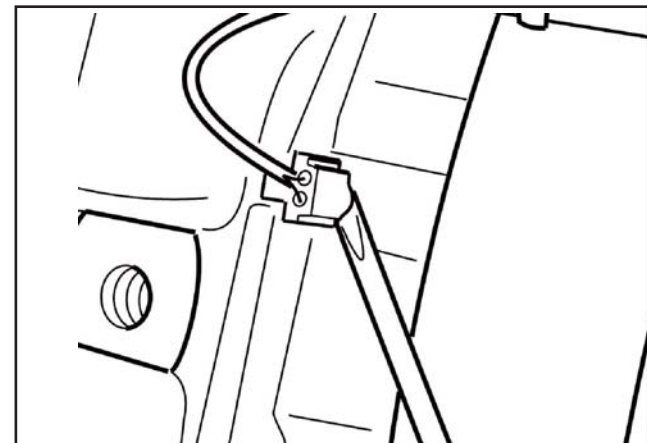

Fig 3.3

Pad Retaining Plate Removal (with Pad Shield if fitted)

The disc brake assembly may incorporate a pad shield attached to the pad retaining plate (Fig. 3.2).

NOTE: DO NOT remove the screws securing the pad shield to the pad retaining plate.

Remove the pad retaining plate screw (Fig 3.2).

Remove the pad retaining plate from the slot in the housing casting and remove the pad retaining plate and, where applicable, pad shield assembly from the brake. Remove the pad springs.

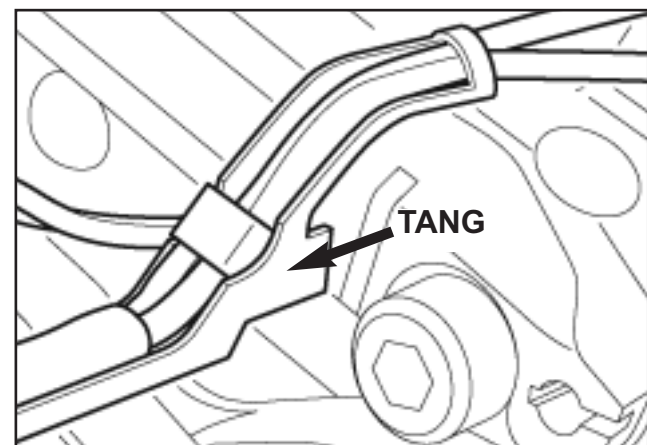

Fig 3.4

3 Pad Replacement

Pad Removal



CAUTION: Before any de-adjustment is made it is important to check the condition of the piston dust excluders. If damage to the dust excluders is evident the piston must be thoroughly cleaned. Failure to do this could result in damage to the secondary piston seals.

NOTE: It may be necessary to de-adjust the brake initially to remove the worn brake pads.

Remove the adjuster stem protecting cap. Locate a suitable 10 mm socket wrench on the adjuster stem and rotate the wrench in an anticlockwise direction as viewed from the air actuator side. (Fig. 3.5)

Do not de-adjust the brake completely, only enough to allow removal of the brake pads.

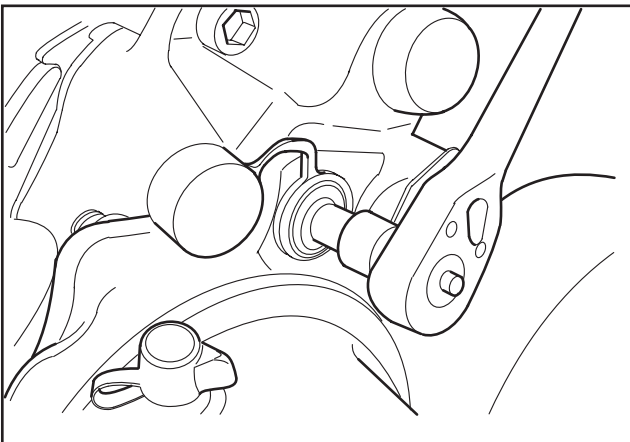

Fig 3.5

NOTE: de-adjustment requires a higher torque than adjustment.



WARNING: Do not de-adjust the brake with the brake pads removed at this stage. Always de-adjust/adjust the brake carefully by hand with a suitable wrench. Never exceed a maximum torque of 40 Nm in either direction and NEVER use power tools.

Cleaning and inspection

With the brake pads removed check the integrity of the guide sleeve and piston excluders. They should be secure and free from any signs of damage. If damaged they should be replaced by following the procedures laid out in **Sections 10 and 11**.

Check that the Brake housing assembly slides freely on the guide sleeves.



WARNING: Take care not to trap fingers whilst checking the sliding action of the brake.

Examine the brake rotor for wear, as detailed in **section 13**.

Also examine for corrosion, grooving and signs of deep cracks as described in **Operational Checks Section 2**. If there is any doubt in the serviceability of any component refer to the vehicle manufacturer for corrective action.

Whilst wearing suitable eye protection remove all traces of scale, dirt etc, from the pad apertures /abutment faces and around the edge of the rotor, particularly that encroaching onto the braking area.

A scraper or old screwdriver supported on the brake body whilst the rotor is rotated will remove most of the corrosion. Finish off if necessary with emery cloth. Remove all traces of scale, dirt etc, from pad apertures and abutment faces that may restrict the movement of the pads and, therefore, prevent sufficient adjustment of the brake.



CAUTION: Ensure any discarded friction product, or cloth contaminated with brake dust, is disposed of in accordance with local environmental regulations.

Where applicable, check the condition of the pad shield attached to the pad retaining plate. If there is any doubt in its suitability for further service, replace following the procedures recommended by the vehicle manufacturer.

3 Pad Replacement

Fitting New Pads



CAUTION: Ensure the friction material is facing the rotor face when fitting new pads. The pads may incorporate a location cut out on the bottom edge of the metal backplate which prevents incorrect fitment of the pads.

De-adjust the brake until, with the housing pulled across, there is a sufficient aperture to fit the outboard pad. Fit the new outboard pad (Fig. 3.6).

Push the housing back towards the rotor until the new pad contacts the rotor face.

NOTE: Care must be taken when sliding the housing on the guide sleeves by hand. Too much force could result in damage to the guide sleeve dust excluders.

Continue to de-adjust the brake until the aperture gap between the Piston Heads and the rotor face is large enough to accept the new inboard pad. With the brake fully de-adjusted it may be necessary to lift the piston excluder by pulling the attached tab just enough to release any trapped air that may be inflating the excluder (Fig. 3.7).

NOTE: Ensure the dust excluder re-seats correctly on the housing and tappet head.

Fit the new inboard pad.



WARNING: Always de-adjust/adjust the brake carefully by hand with a suitable wrench. Never exceed a maximum torque of 40 Nm in either direction and NEVER use power tools.

NOTE: With the brake in a de-adjusted condition, and new pads fitted, it is advisable to carry out a automatic adjuster function test as detailed in **Section 2 Operational Checks**.

Refitting PWWI (where applicable)

Type A

If a new PWWI is to be fitted; position the pad wear cable correctly and carefully clip the pad wear warning cable retainer to the pad retaining plate.

Carefully hold the pad retaining plate complete with PWWI in its location to allow fitment of the plastic sensor blocks.

Ensure the PWWI wiring is routed over the pad backplate, away from the rotor.

Type B & Type C

Fit the plastic plastic blocks of the PWWI into the pads.

Do not use excessive force but ensure they are pushed to the bottom of the slot. (Fig. 3.8).

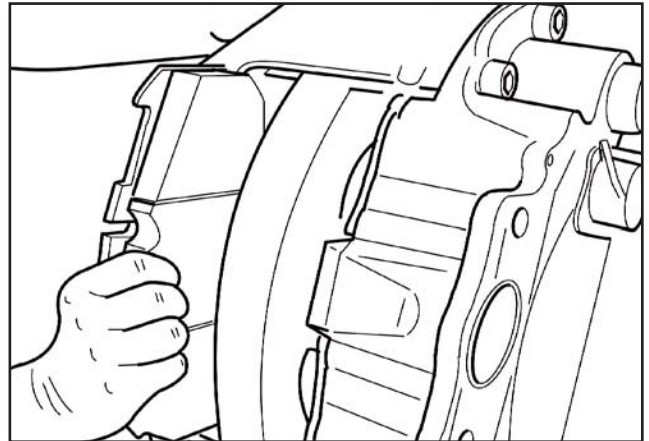

Fig 3.6

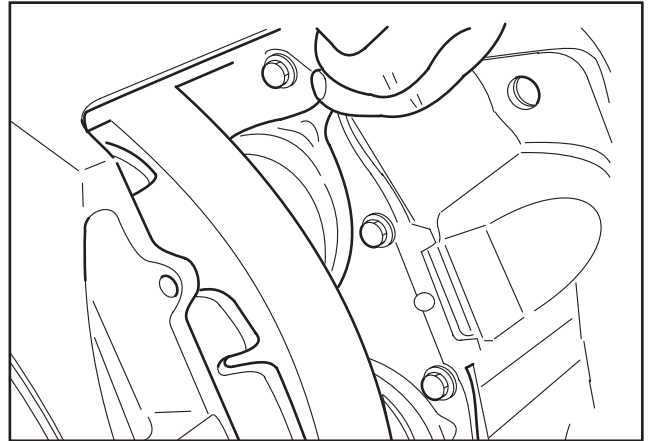

Fig 3.7

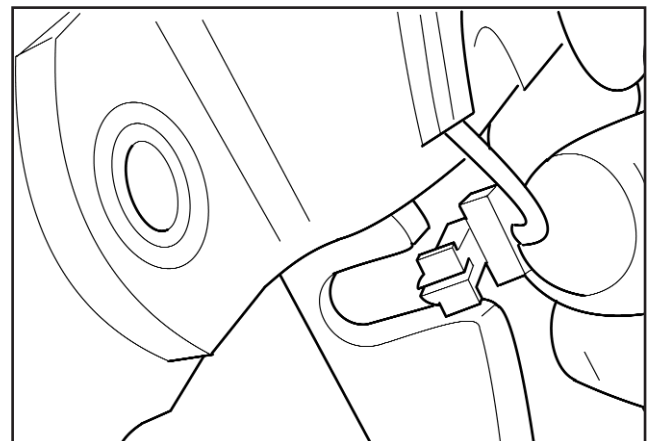

Fig 3.8

3 Pad Replacement

Position the PWWI assembly in the brake, engaging the tang into the housing (Fig 3.9).

Ensure the PWWI wiring is routed over the pad backplate, away from the rotor.

Pad Springs & Retaining Plate

Refit both pad springs ensuring that they are correctly located in the pad back plates. Fig. 3.10 shows the inboard pad spring location and Fig 3.11 the outboard pad spring location.

Insert the pad retaining plate, complete with pad shield where applicable, into the slot in the brake housing.

T Fit a new pad retaining plate screw and torque to 33-40Nm (Fig 3.12).

Reconnect the PWWI to vehicle wiring harness.

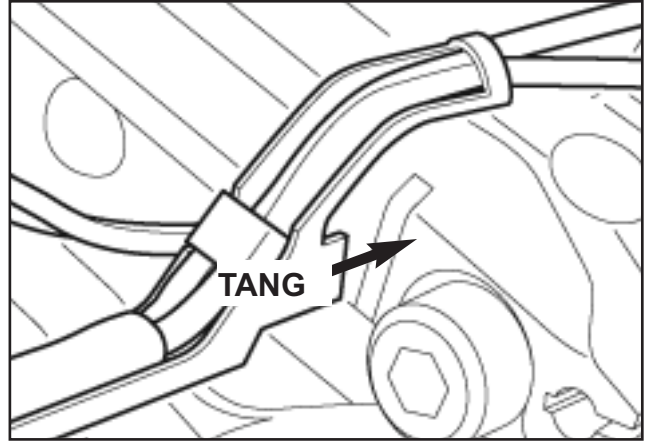

Fig 3.9

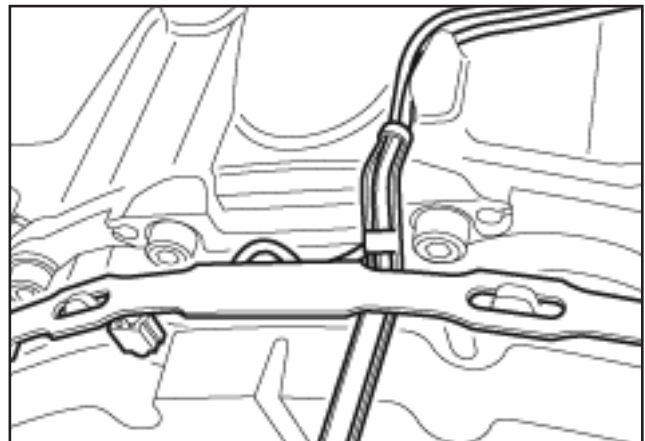

Fig 3.10

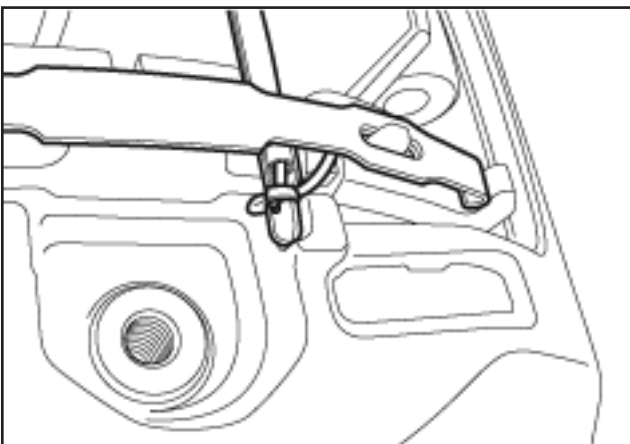

Fig 3.11

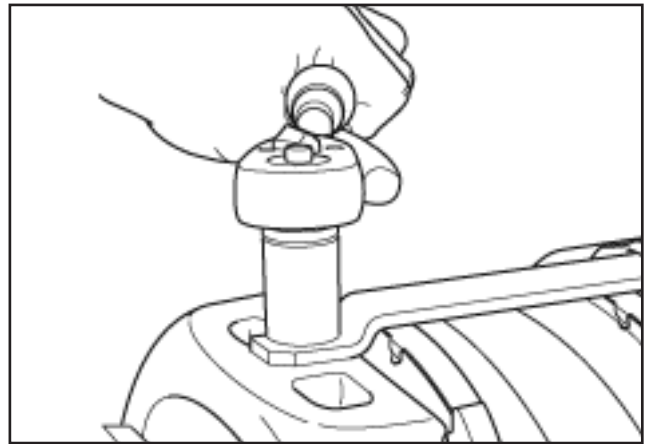

Fig 3.12

3 Pad Replacement

Manual adjustment

To set an initial running clearance locate a 10mm socket wrench on the adjuster stem and turn it clockwise viewed from the air actuator side (Fig 3.13).

Continue to adjust the brake until an increase in resistance is felt and both pads touch the rotor. Turn the adjuster back by 1/2 a turn of the wrench, thus creating a running clearance

Ensure the rotor is free to turn.

NOTE: De-adjustment requires a higher torque than adjustment.

Ensure the sealing area on the cover plate is clean. Always refit the adjuster stem cover



WARNING: Always de-adjust/adjust the brake carefully by hand with a suitable wrench. Never exceed a maximum torque of 40 Nm in either direction and NEVER use power tools.

Charge the air system and apply the brakes 5 times to settle the pads and allow the automatic adjuster to set the correct running clearance. Check that the rotor is free to rotate.

Fit the wheels and tighten the retaining nuts to the vehicle manufacturers torque specification.

Jack the vehicle down to the ground.

Road test.

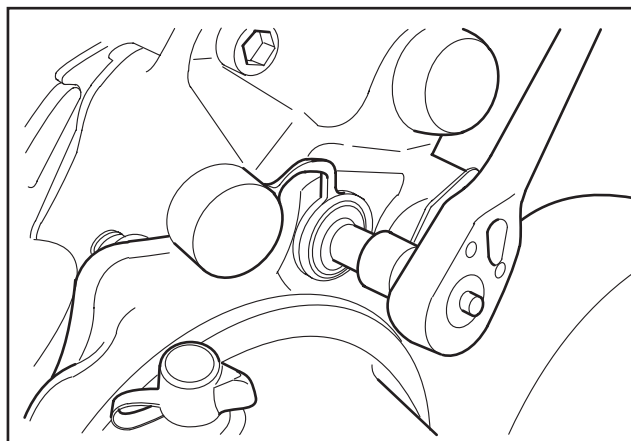

Fig 3.13

3 Pad Replacement

Pad Retaining Plate Replacement

4

pg. 44 Pad retaining plate removal

pg. 45 Pad retaining plate fitment

4 Pad Retaining Plate Replacement

Park the vehicle on hard ground and chock the road wheels. Apply air pressure and fully charge the system to ensure the park brake is fully released.

Wind off the spring brake retraction screw (where appropriate). Jack up the axle and fit suitable axle stands securely. Remove the road wheels and it is advisable to exhaust all air from the system.

Remove any dirt from the brake assembly. Ensure the rubber dust excluders fitted to the tappet heads and guide sleeves are not damaged.



CAUTION: Never use an air line to blow dust from the brake/rotor area. If inhaled any form of dust can at best be an irritant, at worst dangerous. Whenever possible remove dry brake dust with a vacuum brush. Alternatively wipe the areas with a damp cloth, never try to accelerate drying time by using an air line.



CAUTION: Ensure any discarded friction product, or cloth contaminated with brake dust, is disposed of in accordance with local environmental regulations.

Pad Retaining Plate Removal - Separate PWWI

Remove the pad retaining plate screw and pad retaining plate from the brake and discard (Fig 4.1).

The disc brake assembly may incorporate a pad shield attached to the pad retaining plate (Fig. 4.1).

NOTE: DO NOT remove the screws securing the pad shield to the pad retaining plate.

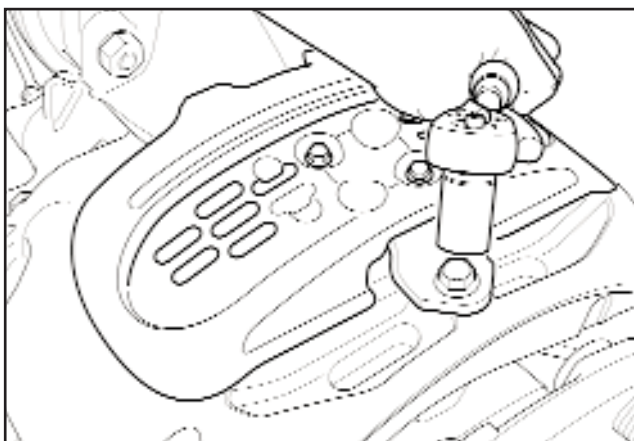

Fig 4.1

Pad Retaining Plate Removal - Attached PWWI

Remove the pad retaining plate screw. Note the position / run of the pad wear cable. Carefully un-clip the pad wear warning cable retainer from the pad retaining plate (Fig 4.2).

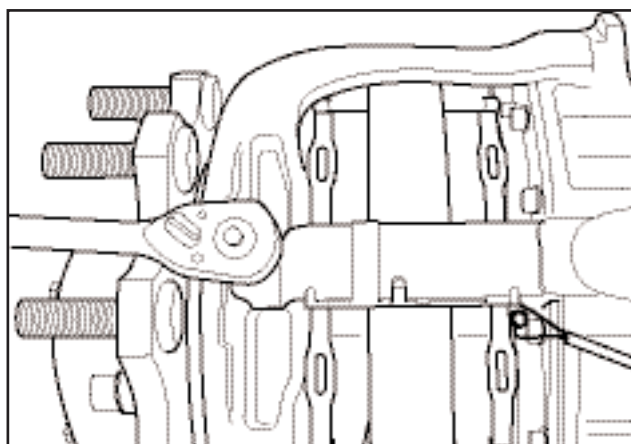

Fig 4.2

4 Pad Retaining Plate Replacement

All Types

Clean loose debris from around the pad springs and check correct positioning. Fig. 4.3 shows the inboard pad spring location and Fig 4.4 the outboard pad spring location.

Clean loose debris from around the location slot **A** for the retaining plate on the brake housing (Fig 4.5)

IMPORTANT: take care to avoid damage to the pad wear warning sensor cables or heads.

If there is any doubt in the serviceability of the pad springs, replace with new or refer to the vehicle manufacturer for corrective action.

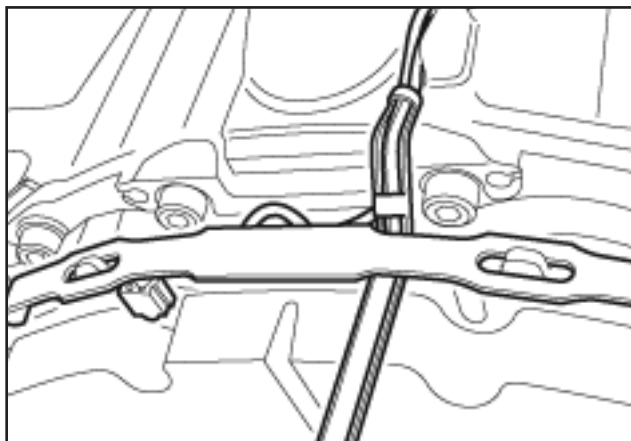

Fig 4.3

Pad Retaining Plate Fitment

Carefully clip the pad wear warning cable retainer to the pad retaining plate where fitted.

T Fit the new pad retaining plate and fixing screw, carefully positioning the pad wear cables where fitted. Tighten the fixing screw to a torque of 34 - 40Nm.

Charge the system with air. Wind in the spring brake retraction screw (where applicable).

Apply the brakes 5 times to settle the pads. Check that the rotor is free to rotate.

Fit the road wheels and tighten the retaining nuts to the vehicle manufacturers' specifications. Jack the vehicle down to the ground and road test.

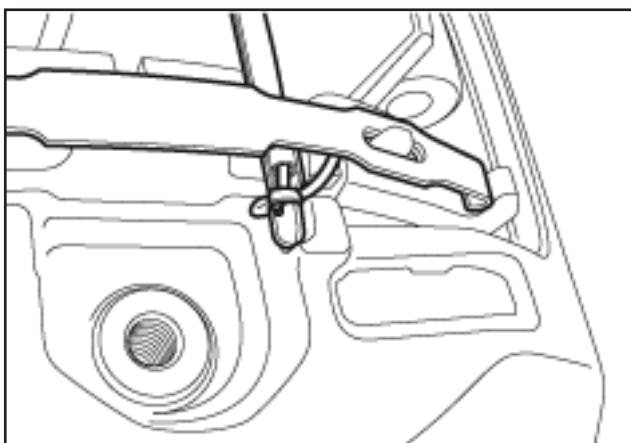

Fig 4.4

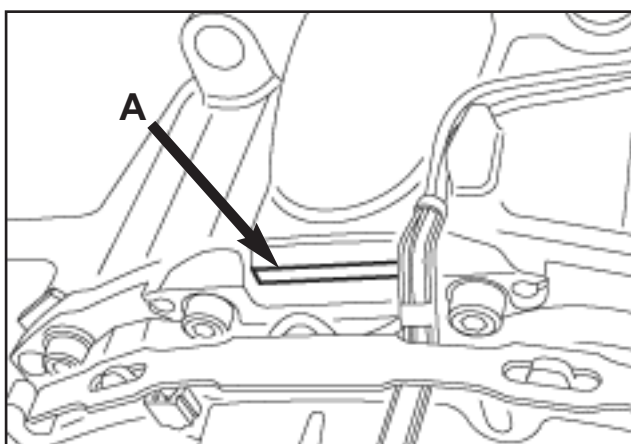

Fig 4.5

4 Pad Retaining Plate Replacement

CWS (Sensor/Switch) Replacement

5

pg. 48 CWS Removal & Fitment

5 CWS (Sensor/Switch) Replacement

Park the vehicle on hard ground and chock the road wheels. Apply air pressure to release the park brake and wind off the spring brake retraction bolt (where appropriate). Jack up the axle and fit suitable axle stands securely.

Remove the road wheels and exhaust all air from the system. Remove any dirt from the brake assembly, ensure the rubber dust excluders are not damaged.



CAUTION: Never use an air line to blow dust from the brake/rotor area. If inhaled any form of dust can at best be an irritant, at worst dangerous. When ever possible remove dry brake dust with a vacuum brush. Alternatively wipe the areas with a damp cloth, never try to accelerate drying time by using an air line.



CAUTION: Ensure any discarded friction product, or cloth contaminated with brake dust, is disposed of in accordance with local environmental regulations.

Sensor/Switch Removal

Where applicable, remove the electronic pad wear sensor (Fig 5.1) or switch (Fig 5.2) retaining screw and discard. Carefully lever out the sensor/switch assembly (Fig 5.3) and discard.

Sensor/Switch Fitment

Clean the sensor/switch access hole and mounting face on the housing and ensure no debris is allowed to fall into the exposed aperture into the housing.

Lightly grease the 'O' ring seal on the new electronic pad wear sensor/switch. Fit the new sensor/switch into the housing, ensuring, where applicable, that the sensor stem locates correctly on the screw head of the manual adjuster (item 17 - exploded views).

NOTE: Only use the grease supplied with replacement components/kits, or that specified by the vehicle manufacturer. Under no circumstance should any other type of grease be used.

NOTE: Ensure the adjuster dust excluder retaining strap is not trapped under the sensor.

NOTE: There are two alternative lengths of sensor retaining screw available, 12mm and 16mm thread length. Ensure the correct retaining screw is used. Failure to use a correct retaining screw could result in the sensor not being securely located which could lead to incorrect readings.

NOTE: During OE fitment an O-ring may be used under the retaining screw. This is an assembly aid and is not required during service operation.

Fit the new retaining screw (Figs 5.1 & 5.2) and tighten the correct torque specified in **Section 14 Servicing & Specification**

Charge the system with air. Wind in the spring brake retraction bolt (where applicable). Refit the road wheels, remove the axle stands and lower the vehicle to the ground.

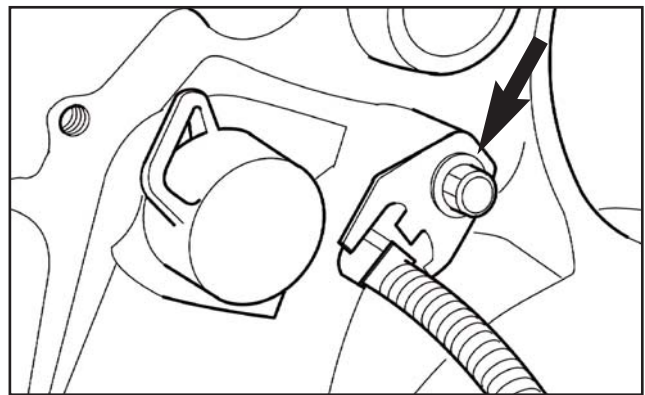

Fig 5.1

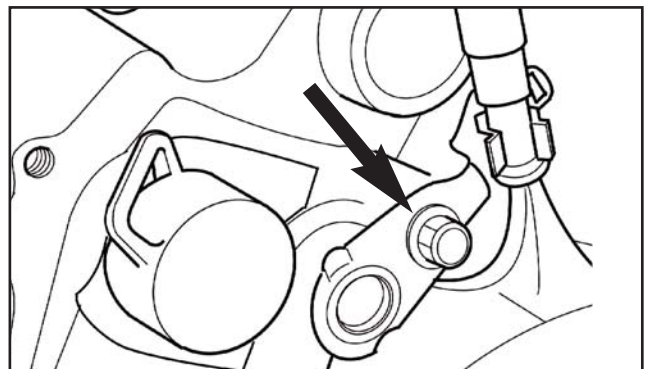

Fig 5.2

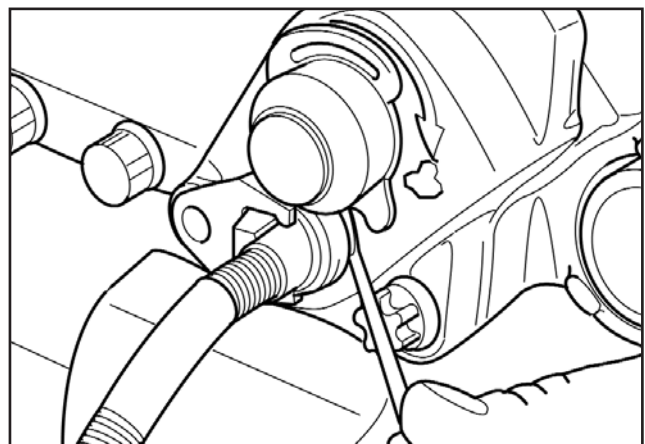

Fig 5.3

Brake Replacement

6

pg. 50 Brake removal

pg. 51 Brake fitment

pg. 51 Actuator Seal Replacement

6 Brake Replacement

Brake Removal

Park the vehicle on level hard ground and chock the road wheels. Apply air pressure to release the park brake and wind off the actuator spring release bolt (where appropriate).



CAUTION: Excessive torque applied to the actuator spring release bolt can lead to damage of internal components. Torque should be applied using hand tools only. Refer to the vehicle manufacturer's instruction for maximum torque value.

Jack up the axle and fit suitable axle stands securely. Remove the road wheels and exhaust all air from the system. Remove any dirt from the Brake assembly, ensure the rubber dust excluders are not damaged.



CAUTION: Never use an airline to blow dust from the brake/rotor area. If inhaled any form of dust can at best be an irritant, at worst dangerous. When ever possible remove dry brake dust with a vacuum brush. Alternatively wipe the areas with a damp cloth, never try to accelerate drying time by using an airline.



CAUTION: Ensure any discarded friction product, or cloth contaminated with brake dust, is disposed of in accordance with local environmental regulations.

Important: The brake assembly number should be noted in order to obtain the correct service kit.

NOTE: If the original brake assembly is to be refitted, observe the caution below.



CAUTION: Before any de-adjustment is made it is important to check the condition of the piston dust excluders. If damage to the dust excluders is evident the piston must be thoroughly cleaned. Failure to do this could result in damage to the secondary piston seals.

The brake assembly may be fitted with either of the following wear indicators, which needs to be disconnected before removing the Brake.

PWWI (Pad Wear Warning Indicator).

Disconnect the PWWI plug where fitted.

CWS (Continuous Wear Sensor/Switch).

NOTE: There are alternative design continuous wear sensors in service. For removal/replacement, refer to Section 5 for the standard sensor which incorporates an integral wiring lead, and refer to Supplement 2 for the cartridge design sensor.

If refitting the original brake assembly, blank off the CWS mounting hole to prevent any dirt ingress into the housing internals. Remove the air actuator from the Brake housing by removing the 2 nuts. (Fig. 6.1). Cover the exposed air actuator mounting aperture with adhesive tape to prevent debris etc. entering the housing. (Fig. 6.2).

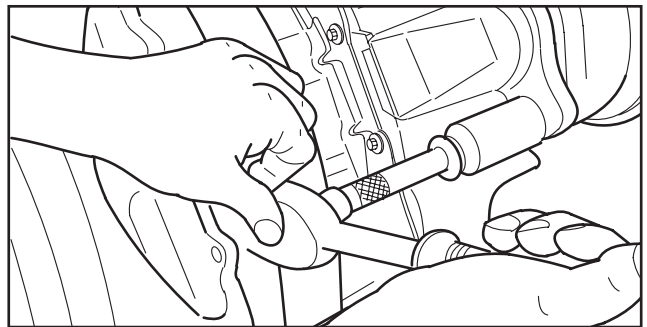

Fig 6.1

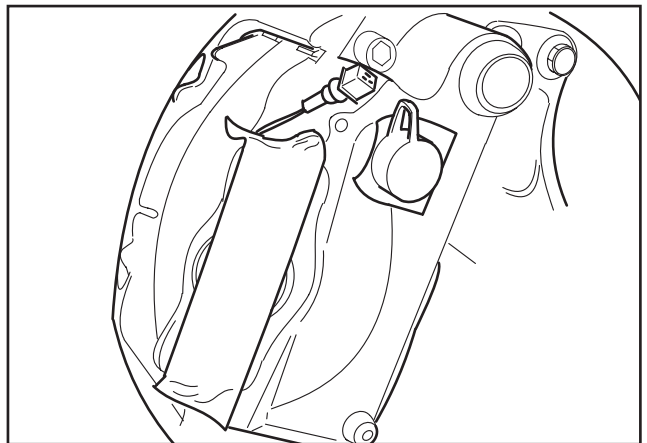

Fig 6.2

NOTE: When the actuator has been removed, where applicable, ensure it is adequately supported so that no strain is placed on the air line or CWS harness.

Remove the pads and, where applicable, the PWWI as described in **Section 3 Pad replacement**. The Brake can now be removed from the axle by removing the carrier mounting screws, and where applicable rotor shield, following the vehicle manufacturers instructions.

6 Brake Replacement

NOTE: The Brake assembly is heavy, up to approximately 50kg (110lbs). Ensure you have the help of an assistant and the weight of the Brake is supported when removing the fixing screws to avoid possible damage to the threads.



CAUTION: When lifting the Brake assembly avoid trapping fingers between the Brake housing and carrier which are free to slide relative to each other. Also prevent any sudden movement, which may result in rapid sliding of the components, which may cause damage to rubber dust excluder areas.



CAUTION: Certain applications incorporate dowel bushes in the carrier which locate in the axle. Before fitting the brake assembly check that the dowel bushes have not been damaged. If any damage to the dowel bushes is identified the bushes must be replaced, refer to section 12.

Brake fitment

Ensure all mounting faces are clean and free from corrosion. With the help of an assistant, carefully lower the Brake assembly into position on the axle mounting. Avoid excessive movement of the Brake during location and do not allow the Brake to drop into position on the axle, either action could result in damaged to the slide pin dust excluders. Fit new fixing screws and torque to the vehicle manufacturers recommendations. Refit the rotor shield, where applicable, following the vehicle manufacturers instructions.

New Brake Assemblies

NOTE: if fitting a new brake assembly, the transit peel out gasket must be removed from the Actuator seal (Fig 6.3) before fitting the Air Actuator.



Fig 6.3

Original Brake Assemblies

NOTE: if replacing the original brake assembly, remove the adhesive tape from the air actuator mounting aperture.

Check the condition of the actuator seal in the housing. If there is any doubt in the suitability for further service replace the seal following the procedure detailed below;

Actuator Seal Replacement

Using a suitable screwdriver carefully lever out the actuator seal (Fig 6.4).

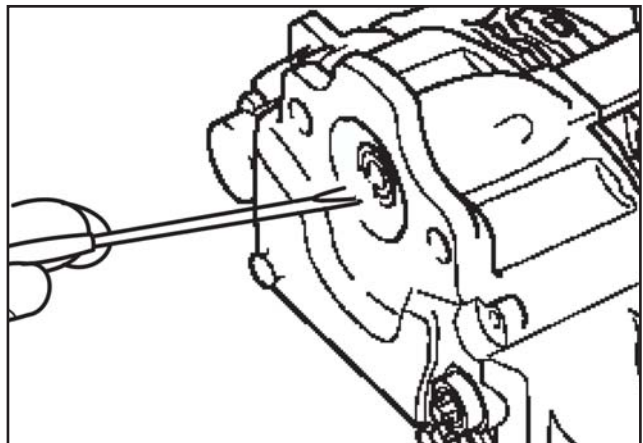

Fig 6.4

Clean the exposed seal location in the housing assembly with a suitable Brake Cleaner and examine for damage or excessive wear.

Locate the new actuator seal in position in the housing assembly (Fig. 6.5).

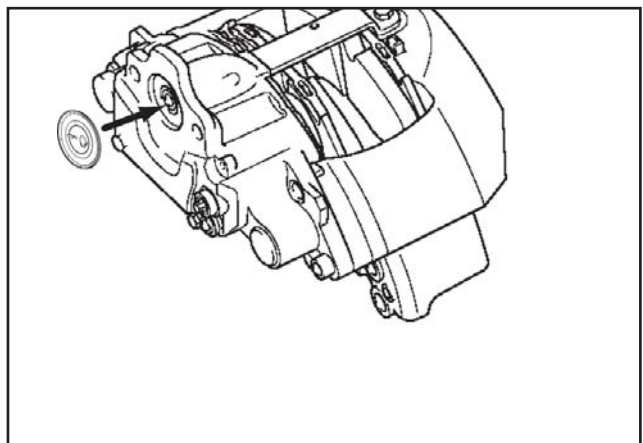

Fig 6.5

6 Brake Replacement

NOTE: Ensure the seal is fitted the correct way round when pressing into the housing assembly (Fig 6.6).

Using a suitable size socket carefully tap the seal into position (Fig 6.7).

NOTE: The transit peel out gasket must be removed from the new Actuator seal (Fig 6.3) before fitting the Air Actuator.

All Brakes

Lightly grease the operating shaft pocket with the appropriate grease. (Fig. 6.8)

NOTE: Only use the grease supplied with replacement components/kits, or that specified by the vehicle manufacturer. Under no circumstance should any other type of grease be used.

Offer the air actuator to the housing assembly ensuring the mounting faces and push rod are clean and the push rod is correctly located in the operating shaft pocket.

T Secure the air chamber to the housing assembly and torque to the vehicle manufacturers recommendations.

OR

Initially tighten the 2 nuts to a pre-torque of 80 -100Nm, this ensures the actuator seals and does not distort.

Apply a final torque of 180 - 210 Nm

Where applicable remove the blanking protection from the CWS aperture and refit the CWS.

NOTE: There are alternative design continuous wear sensors in service. For refitment refer to Section 5 for the standard sensor which incorporates an integral wiring lead, and refer to Supplement 2 for the cartridge design sensor.

Refit, or fit new, pads and where applicable the PWWI, set the initial running clearance and test as described in **Section 3 Pad replacement.**

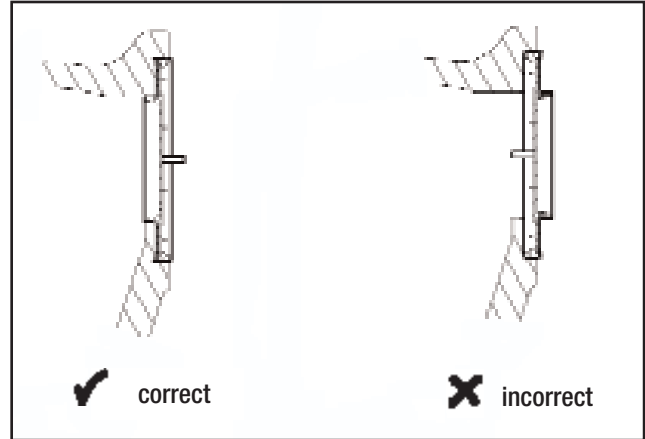

Fig 6.6

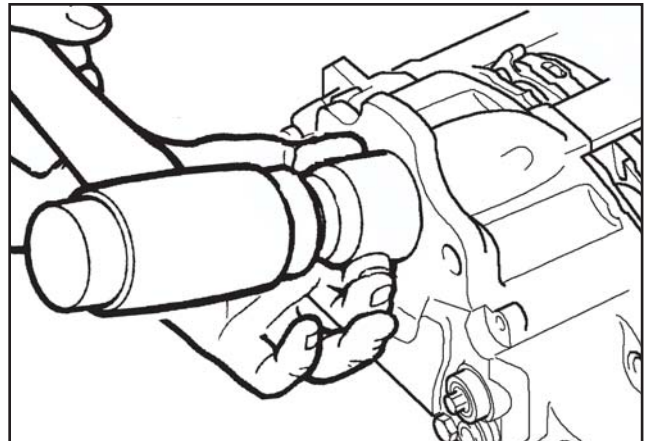

Fig 6.7

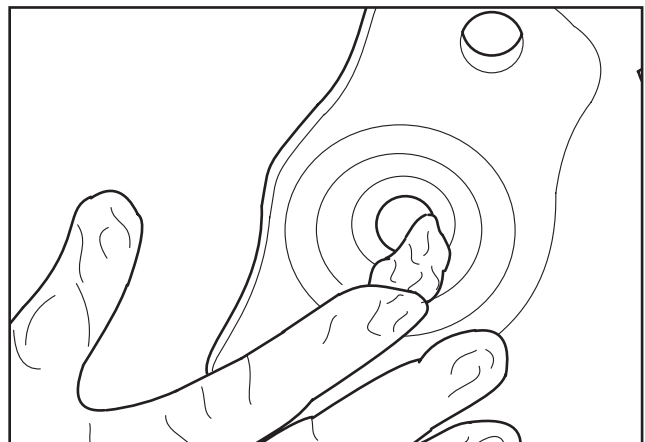

Fig 6.8

Bridge Replacement

7

pg. 54 Removing & Fitting the Bridge

7 Bridge Replacement

Removing the Bridge

Remove the pads and PWWI where fitted as described in **Section 3 Pad replacement**.

Support the bridge by hand and loosen the 4 bridge screws. (Fig. 7.1). Remove and discard these screws (they are not reusable). Carefully remove the bridge. (Fig. 7.2)

NOTE: Ensure the housing does not slide off the guide sleeves.

Ensure that the mating surface of the housing is clean. Check the guide sleeve dust excluder for signs of damage and secure location (Fig. 7.3). Replace if in any doubt, following procedure laid out in **Section 11 Guide Sleeve, Dust Excluder Retainer & Bushes**.

Pay special attention for correct location **A** and any excluder damage, such as splits or tears **B**. (Fig. 7.4)

Fitting the Bridge

Locate the bridge in position against the Brake housing, take care not to damage the guide sleeve excluders. Whilst supporting the weight of the bridge fit the 4 new bridge screws.

NOTE: There are alternative bridge retaining screws in service. Tighten the screws to the torque specified in **section 14 Service and Specifications**.

Refit the pads and where applicable the PWWI, set the initial running clearance and test as described in **Section 3 Pad replacement**.

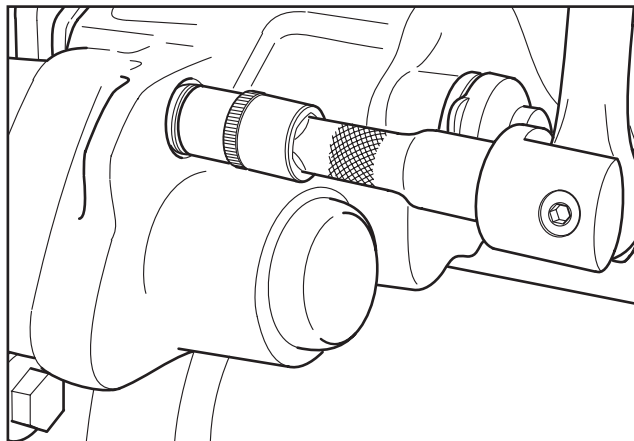

Fig 7.1

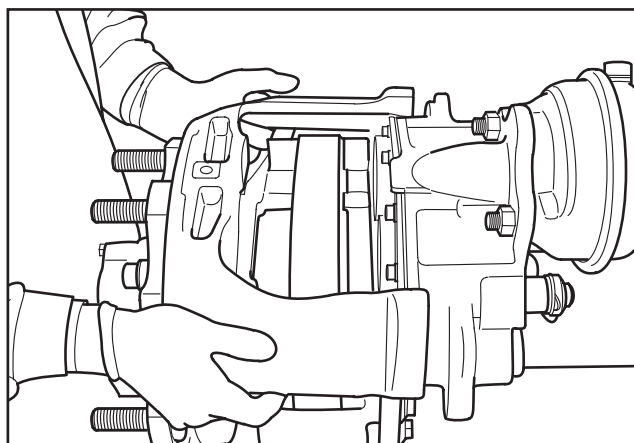

Fig 7.2

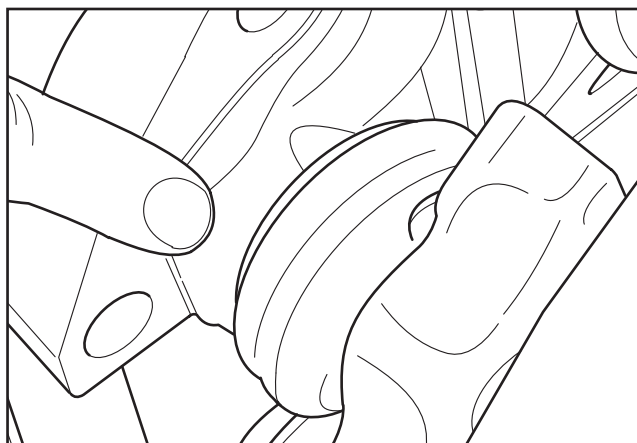

Fig 7.3

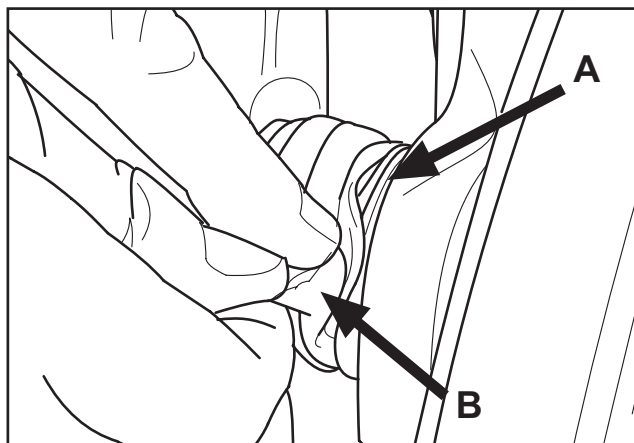

Fig 7.4

Housing & Visual Wear Indicator Replacement

8

- pg. 56 Removing the housing assembly
- pg. 56 Removing or retaining the visual wear indicator
- pg. 57 Fitting the visual wear indicator
- pg. 57 Fitting housing assembly
- pg. 58 Fitting new end caps

8 Housing & Visual Wear Indicator Replacement

Removing the Housing assembly



CAUTION: The screws which secure the piston housing to the brakes assembly housing **MUST NOT** be removed. Evidence of tampering with the screws will void any warranty claim.

Support the vehicle and where applicable, remove the CWS.

NOTE: There are alternative design continuous wear sensors in service. For removal/replacement, refer to Section 5 for the standard sensor which incorporates an integral wiring lead, and refer to Supplement 2 for the cartridge design sensor.

If refitting the original housing assembly, blank off the CWS mounting hole to prevent any dirt ingress into the housing internals.

Remove the actuator as described in **Section 6 Brake replacement**.

NOTE: When the actuator has been removed, where applicable, ensure it is adequately supported so that no strain is placed on the air line or CWS harness.

Remove the pads as described in **Section 3 Pad replacement**. Remove the bridge as described in **Section 7 Bridge replacement**.

IMPORTANT: The brake assembly number should be noted in order to obtain the correct service kit.

Carefully slide the housing off the guide sleeves which are secured to the carrier. (Fig. 8.1). It is advisable to retain the visual wear indicator and spring, where applicable, in position before removing the housing (Fig 8.2). This prevents the spring load from ejecting the indicator as the housing is removed. Ensure the visual wear indicator is not damaged.

Clean and inspect the carrier for signs of damage or wear paying particular attention to the pad abutment areas and guide sleeves (Fig. 8.3).

If any doubt exists as to the suitability for further service replace with new guide sleeves and if necessary a new carrier. Clean and inspect the brake rotor as described in **Section 2 Operational checks**.

Visual Wear Indicator Replacement

Release the retention on the visual wear indicator shaft and slide the shaft out of the housing with the spring.

NOTE: If the visual wear indicator has become seized or broken



in the housing and cannot be removed by hand, carefully tap out using a suitable drift tool and mallet.

When the visual wear indicator has been removed, clean any debris or corrosion from the location hole in the housing.

CAUTION: Do not attempt to drill out a seized visual wear indicator. This could result in damage to the housing assembly which would subsequently require replacement.

Fit the new spring to the new indicator shaft. Slide the indicator shaft into the housing and retain as before (Fig. 8.2).

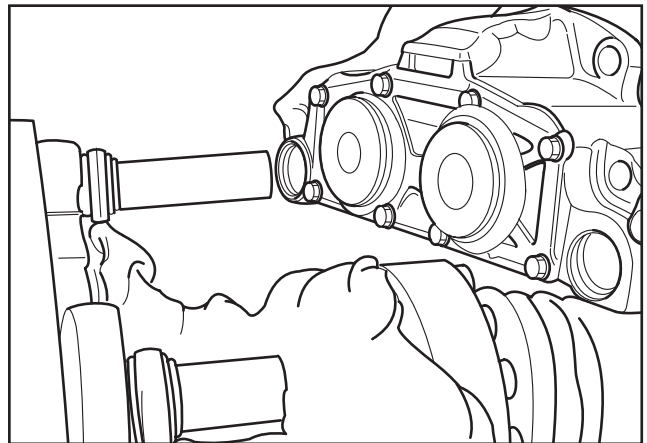

Fig 8.1

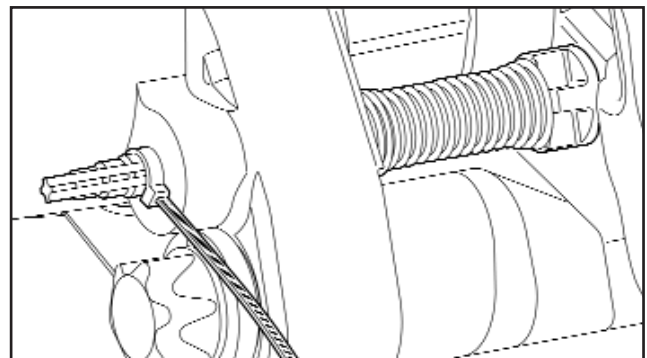

Fig 8.2

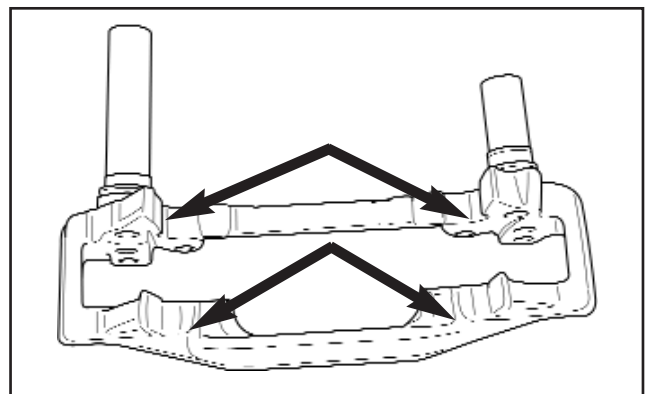

Fig 8.3

8 Housing & Visual Wear Indicator Replacement

Fitting Housing assembly

Lightly lubricate the inner surface of the new guide sleeve dust excluders and fit over the guide sleeves. Ensure that the dust excluder bead is correctly located on the retainer fitted to the carrier. (Fig. 8.4)

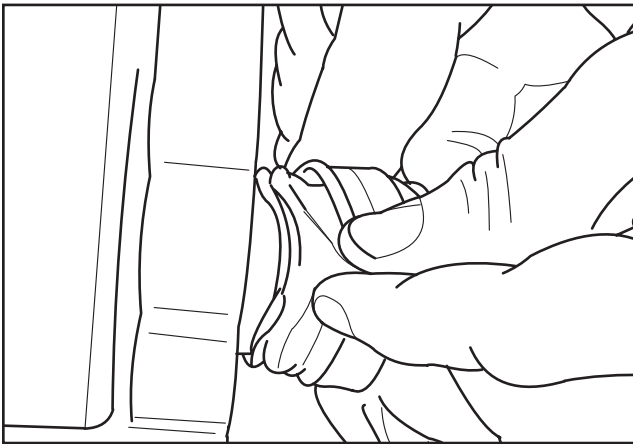

Fig 8.4

Apply grease to the guide sleeve and housing guide sleeve bores. (Fig. 8.5)

NOTE: Only use the grease supplied with replacement componenuts/kits, or that specified by the vehicle manufacturer. Under no circumstance should any other type of grease be used.

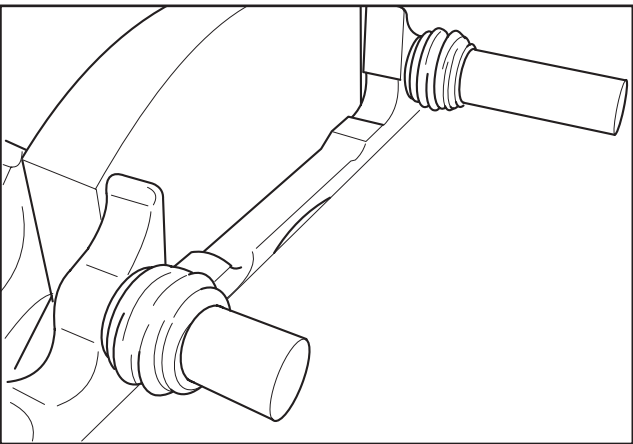

Fig 8.5

Carefully slide the housing assembly into position on the guide sleeves secured to the carrier (Fig. 8.6)



WARNING: Take care not to damage the guide sleeve dust excluder when locating the Housing assembly onto the carrier.

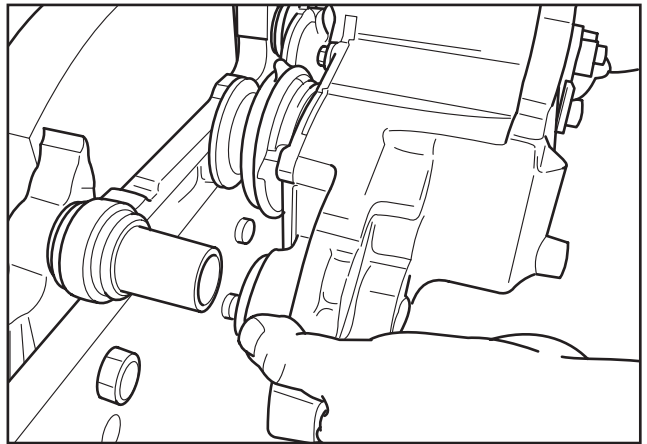

Fig 8.6

Locate the guide sleeve dust excluders onto the housing retainers.(Fig. 8.7)

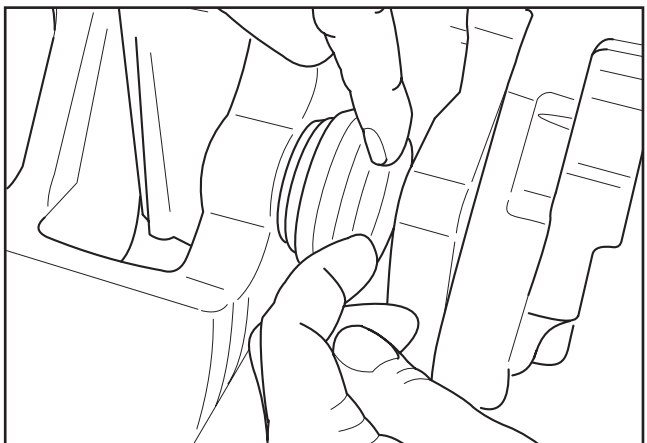

Fig 8.7

8 Housing & Visual Wear Indicator Replacement

Ensure the dust excluders are located correctly on both carrier and housing retainers. (Fig. 8.8)

Slide the housing backwards and forwards several times to check the smooth movement of the housing on the guide sleeves.

NOTE: Care must be taken when sliding the housing on the guide pins by hand. Too much force could result in damage to the guide pin dust excluders



Fig 8.8

Fitting new End Caps

There are variations in brake design currently in service. Follow the appropriate procedure below to fit the new end caps.

Axial 195/225/250 - Early Design

Using a copper faced mallet and suitable arbor, carefully tap one of the new end caps into the housing until it retains itself (Fig 8.9)

Repeat for the second end cap. Using the arbor tap the end caps in until they meet the dimensions 1.75mm - 2,25mm for the short guide sleeve (Fig. 8.10) and 6.4mm - 5.8mm for the long guide sleeve (Fig. 8.11) .

NOTE: The end caps for long and short pins must be fitted to the different dimension as shown in Fig 8.10 for short pin & Fig 8.11 for long pin. The dimensions must be checked to ensure that they do not exceed the stated maximum figures.

NOTE: if the cap is pushed in below the minimum stated, this would restrict full movement of the housing assembly.

Axial 195/225/250 - Later Design

Radial 225 - All Levels

Using a copper faced mallet and suitable arbor, carefully tap one of the new end caps into the housing until it retains itself (Fig 8.9)

Repeat for the second end cap. Using the arbor tap the end caps in until they meet the dimension 1.75mm - 2.25mm (Fig. 8.10).

NOTE: The dimensions must be checked to ensure that they do not exceed the stated maximum figures.

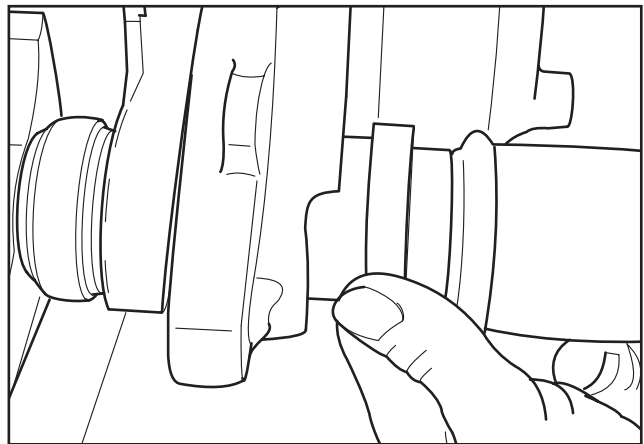

Fig 8.9

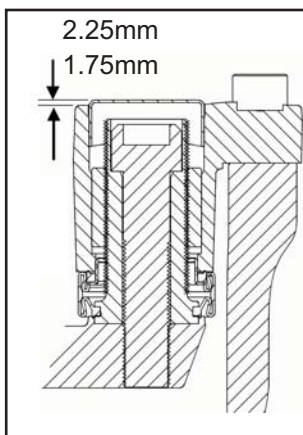

Fig 8.10

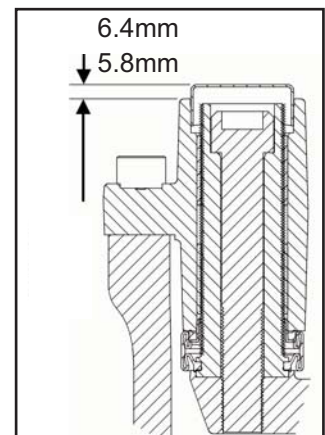

Fig 8.11

8 Housing & Visual Wear Indicator Replacement

When the end caps have been correctly fitted, check again the free movement of the housing assembly on the guide sleeves. Slide the housing backwards and forwards several times to check the smooth movement of the housing on the guide sleeves. Slide the housing to check the location of the dust excluders (Fig. 8.12).

This can be identified by the excluder collapsing due to pressure change within the slide pin mechanism.

NOTE: Care must be taken when sliding the housing on the guide pins by hand. Too much force could result in damage to the guide pin dust excluders

Refit the Bridge as described in **Section 7 Bridge replacement.**



WARNING:

Always use new bridge bolts/screws. Once removed bridge bolts/screws should not be re-used.

Remove the clip/retainer from the visual wear indicator (Fig 8.13).where applicable

Where applicable remove the blanking protection from the CWS aperture and refit the CWS.

NOTE: There are alternative design continuous wear sensors in service. For refitment refer to Section 5 for the standard sensor which incorporates an integral wiring lead, and refer to Supplement 2 for the cartridge design sensor.

Refit the air actuator as described in **Section 6 Brake replacement.**

Refit the pads and where applicable the PWWI, set the initial running clearance and test as described in **Section 3 Pad replacement.**

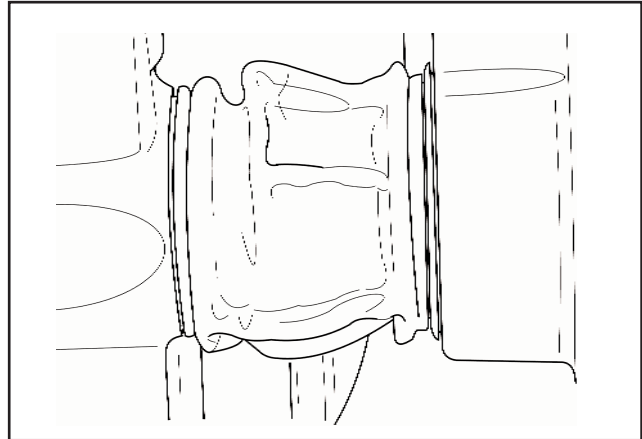

Fig 8.12

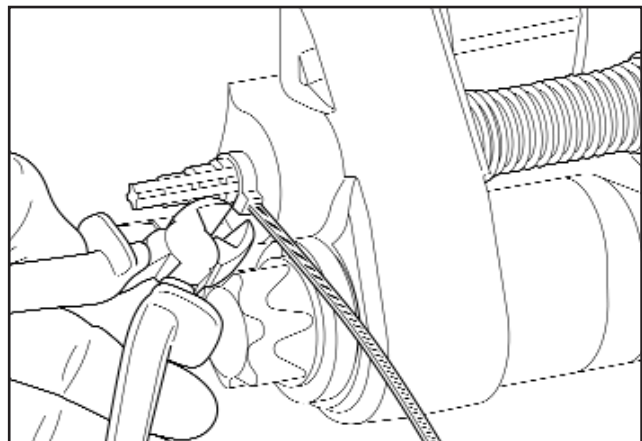

Fig 8.13

8 Housing & Visual Wear Indicator Replacement

Carrier Replacement

9

pg. 62 Carrier removal

pg 63 Carrier fitment

9 Carrier Replacement

Removing the Carrier

Support the vehicle and where applicable, remove the CWS.

NOTE: There are alternative design continuous wear sensors in service. For removal/replacement, refer to Section 5 for the standard sensor which incorporates an integral wiring lead, and refer to Supplement 2 for the cartridge design sensor.

If refitting the original housing assembly, blank off the CWS mounting hole to prevent any dirt ingress into the housing internals.

Remove the actuator as described in **Section 6 Brake replacement**.

NOTE: When the actuator has been removed, where applicable, ensure it is adequately supported so that no strain is placed on the air line or CWS harness.

Remove the pads as described in **Section 3 Pad replacement**.
Remove the bridge as described in **Section 7 Bridge replacement**.

Remove the housing assembly as described in **Section 8 Housing replacement**.

NOTE: Where applicable, It is advisable to record the position of the SHORT & LONG, or LARGER & SMALLER, diameter guide sleeves on the original carrier before removal (Fig 9.1). This will ensure the guide sleeves are fitted in the correct position on the new carrier

If the guide sleeve dust excluders remain on the carrier after removing the housing, carefully detach the excluders from their location on the carrier and slide them off the guide sleeves (Fig. 9.2). Discard the old guide sleeve excluders.

NOTE: Certain applications use two piece stainless steel guide sleeves (Fig. 9.3a), or guide sleeves which incorporate three ball bearings (Fig. 9.3b) as original equipment. Ensure the parts provided in the Meritor Service Kit match, or are compatible with the guide sleeves being replaced.

Remove and discard the guide sleeve screws retaining the guide sleeves to the carrier. (Fig. 9.4) - If necessary carefully release the guide sleeves using a rubber or soft metal hammer from their location on the carrier.

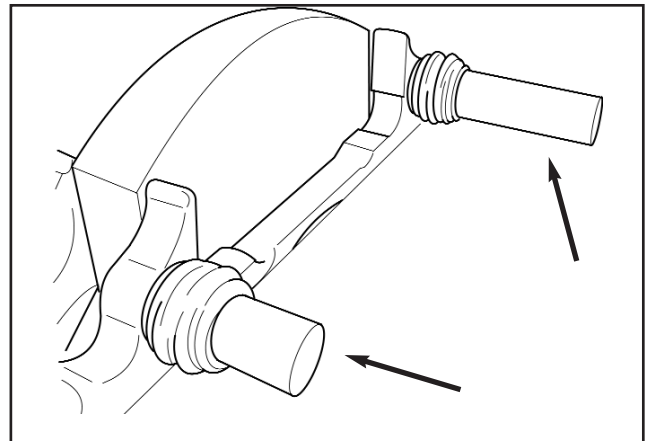

Fig 9.1

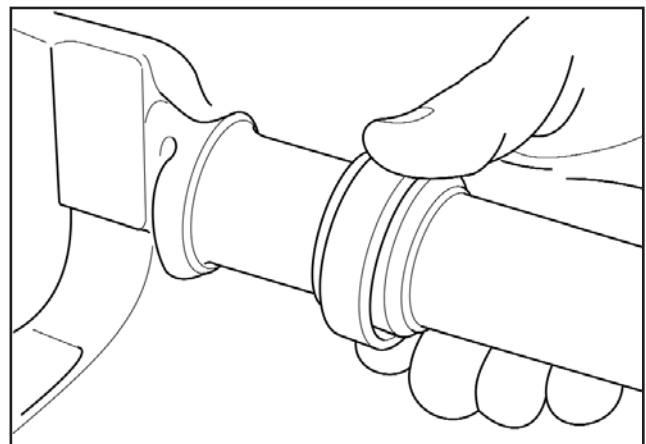

Fig 9.2

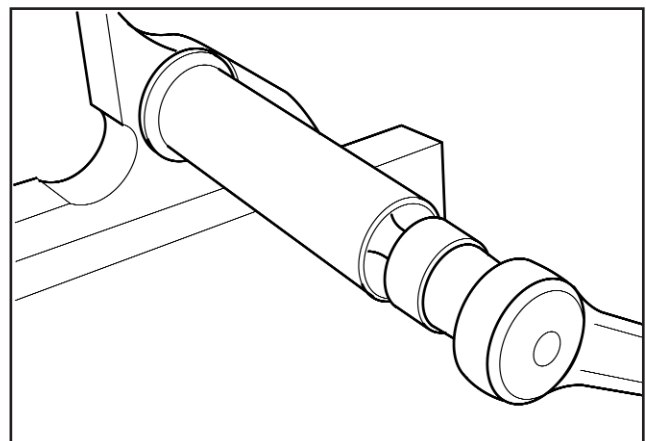

Fig 9.4

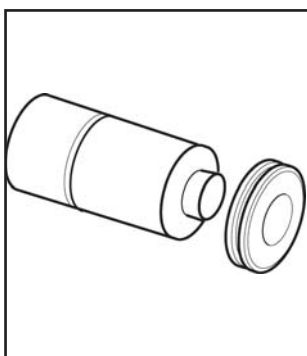

Fig 9.3a

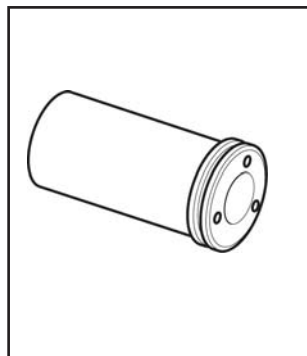

Fig 9.3b

9 Carrier Replacement

Cleaning & Inspection

Inspect the integrity of the piston excluders. They should be secure and free from any signs of damage. If damaged they should be replaced as described in **Section 10**.

Clean and inspect the guide sleeves removed from the carrier. If there is evidence of damage, wear or corrosion replace with new items as described in **Section 11**.

NOTE: If re-using the original two piece stainless steel guide sleeves (fig 9.3) ensure the dust excluder retaining sections (1) are refitted correctly on the guide sleeves (2) if they become detached during guide sleeve removal process.

NOTE: If replacing the guide sleeves the Meritor Aftermarket Service Kits contain the conventional one piece guide sleeves, which are completely interchangeable with the two piece guide sleeves.

Remove existing grease from the guide sleeve bores in the housing and inspect the bushes and dust excluder retainers. If there is evidence of damage, wear or corrosion replace the bushes and retainers as described in **Section 11** or housing assembly as described in **Section 8**.



CAUTION: Ensure any grease removed from the assembly/components, or contaminated cloth, is disposed of in accordance with local environmental regulations.

Fitting a new Carrier



CAUTION: Certain applications incorporate dowel bushes in the carrier which locate in the axle. Before fitting the carrier assembly check that the dowel bushes have not been damaged. If any damage to the dowel bushes is identified the bushes must be replaced, refer to section 12.

Locate the new carrier correctly on the vehicle axle and secure with new retaining bolts. Tighten the bolts to the torque specified by the vehicle manufacturer.

Lightly lubricate the guide sleeves, with the grease provided in the service kit (Fig 9.5).

NOTE: Only use the grease supplied with replacement components/kits, or that specified by the vehicle manufacturer. Under no circumstance should any other type of grease be used.

Locate the guide sleeves on the new carrier and loosely retain with the new guide sleeve screws provided. If fitting guide sleeves which incorporate ball bearings, lightly grease the underside of the screw heads before fitting.

NOTE: It is important to apply grease to the underside of the screw heads to achieve the correct torque and angle tightening method.

NOTE: Only use the grease supplied with replacement components/kits, or that specified by the vehicle manufacturer. Under no circumstance should any other type of grease be used.

NOTE: Ensure, where applicable, the LONG & SHORT or LARGER & SMALLER diameter guide sleeves are fitted to the new carrier in the correct position.



Tighten the new guide pin screws to the correct torque, as specified in **section 14 Servicing & Specifications**.

Lightly lubricate the inner surfaces of the new guide sleeve excluders with grease and ensure they are located correctly on the carrier (Figs. 9.6). Apply grease to the guide sleeve and housing guide sleeve bores.

NOTE: Only use the grease supplied with replacement components/kits, or that specified by the vehicle manufacturer. Under no circumstance should any other type of grease be used.

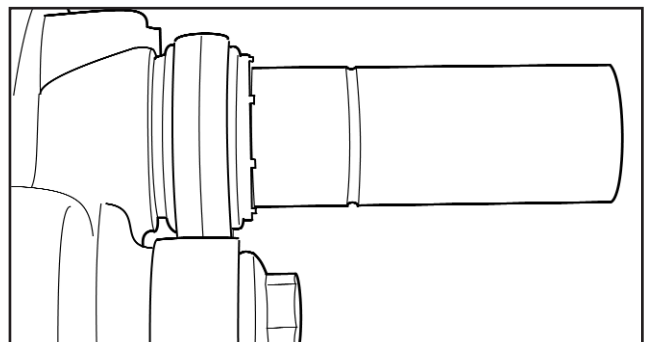

Fig 9.5

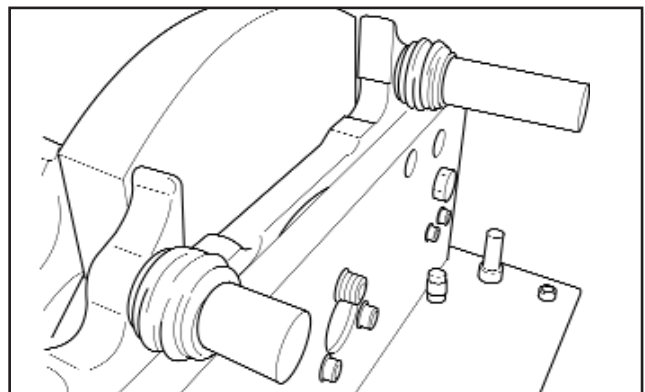

Fig 9.6

9 Carrier Replacement

Carefully slide the housing assembly into position on the guide sleeves secured to the carrier. Locate the guide sleeve excluders onto the housing retainers (Fig 9.7).

NOTE: Take care not to damage the guide sleeve excluders when locating the housing on to the carrier.

Ensure the dust excluders are located correctly on both carrier and housing retainers (Fig 9.8). Hold the housing in position for a short time to allow any trapped air to bleed from the dust excluders. Slide the housing backwards and forwards several times to check the smooth movement of the guide sleeves.

Slide the housing to check the location of the dust excluders (Fig 9.9)

Using the new bridge bolts provided, refit the bridge as described in **Section 7 Bridge replacement.**



CAUTION:

Always use new bridge screws. Once removed bridge screws must not be re-used.

Where applicable refit the CWS .

NOTE: There are alternative design continuous wear sensors in service. For removal/replacement, refer to Section 5 for the standard sensor which incorporates an integral wiring lead, and refer to Supplement 2 for the cartridge design sensor.

Refit the air actuator as described in **Section 6 Brake replacement.**

Refit the pads and where applicable the PWWI, set the initial running clearance and test as described in **Section 3 Pad replacement.**

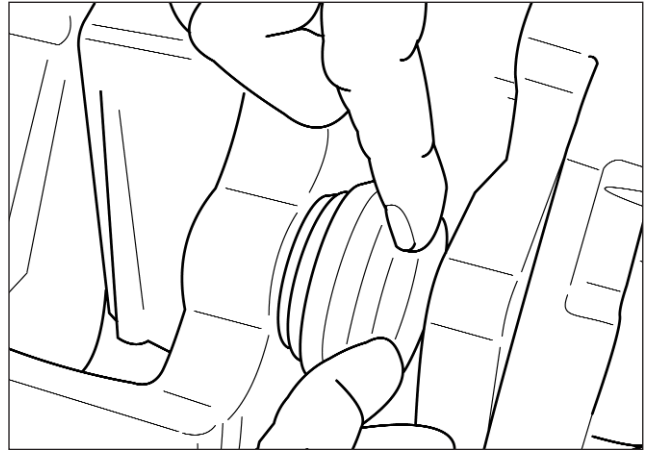

Fig. 9.7



Fig. 9.8

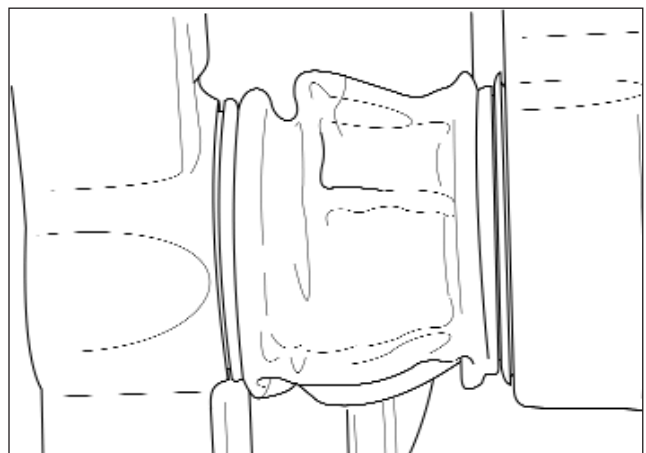

Fig. 9.9

Piston Head & Dust Excluder Replacement

10

pg. 66 Piston Dust Excluder Removal

pg. 66 Piston Head Replacemet

pg. 67 Fitting Dust Excluder

10 Piston Head & Dust Excluder Replacement

Piston Head & Dust Excluder Replacement

Remove the brake pads as described in **Section 3 Pad replacement**.

Using the manual adjuster stem, adjust out the piston assemblies approximately 40 mm. (Figs.10.1 & 10.2)

Adjusting out the piston assemblies aids removal of the piston dust excluders and where necessary, the piston heads.

NOTE: de-adjustment requires a higher torque than adjustment.



WARNING: Always de-adjust/adjust the brake carefully by hand with a suitable wrench. Never exceed a maximum torque of 40 Nm in either direction and NEVER use power tools.

Piston Dust Excluder Removal

Remove the piston dust excluders and discard.
Clean the Piston Heads and housing retainers with a suitable brake cleaner.

Check the piston heads for damage or excessive corrosion. If there is any doubt in their suitability for further service replace following the Piston Head Replacement procedure detailed below.

Check condition of piston dust excluder retainers and piston shafts. If damage, excessive corrosion or wear is present, the housing assembly or brake assembly should be replaced as described in **Section 8 Housing Replacement** or **Section 6 Brake replacement**.

NOTE: It is not necessary to remove the piston heads to replace dust excluders.

Piston Head Replacement

Carefully tap the piston heads off the piston shafts (Fig 10.3).



CAUTION: Do not use excessive force or heavy hammer blows to remove the piston heads. Do not damage the piston shafts. If the piston shafts are damaged when removing the piston heads the housing assembly or brake assembly should be replaced.

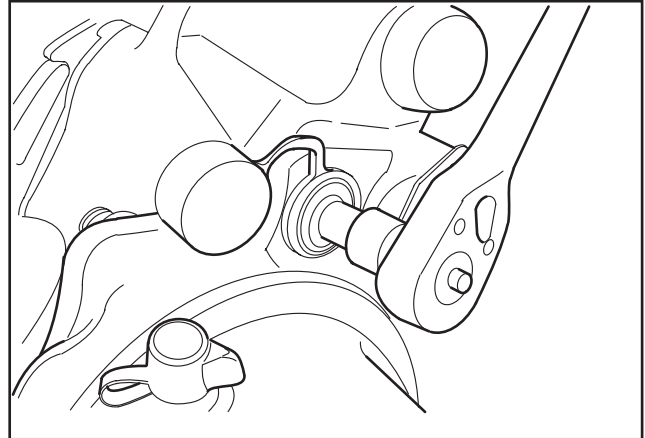

Fig 10.1

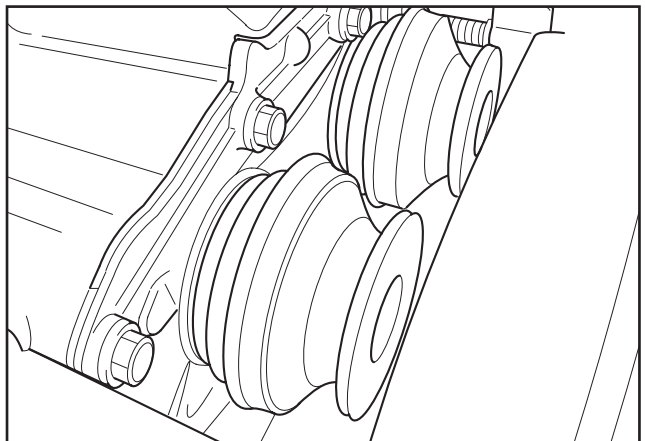

Fig 10.2

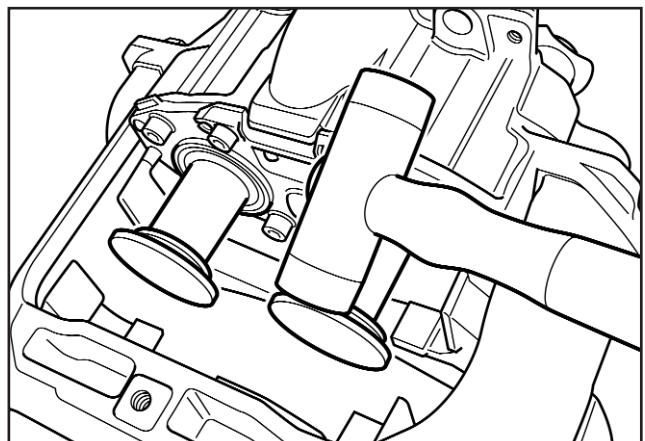

Fig 10.3

10 Piston Head & Dust Excluder Replacement

The piston shafts incorporate a retaining ring A (Fig 10.4).

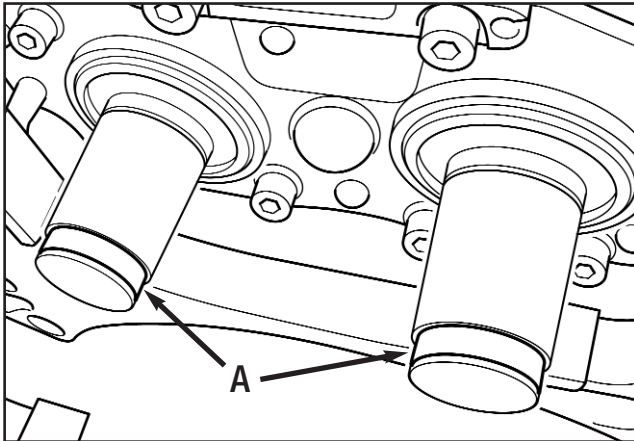

Fig 10.4

Locate a new piston head onto the piston shaft and press firmly to secure (Fig 10.5). Repeat for the second piston head.

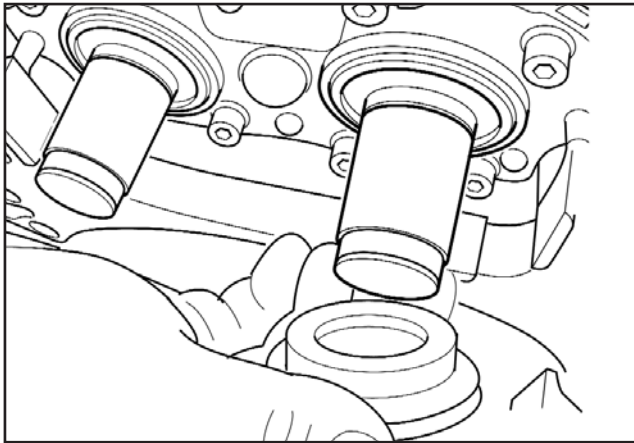

Fig 10.5

Fitting new Piston Dust Excluders

Lightly lubricate the piston shafts with grease supplied in kit.

NOTE: Only use the grease supplied with replacement components/kits, or that specified by the vehicle manufacturer. Under no circumstance should any other type of grease be used.



WARNING: When fitting new piston excluders, do not use any grease to aid assembly. Hands should be clean and free from grease. To disregard this instruction may cause premature failure of piston excluders.

Carefully feed one of the new piston dust excluders over a piston head. (Fig. 10.6)

Do not at this stage fit the excluder bead into the retaining groove in the brake housing.

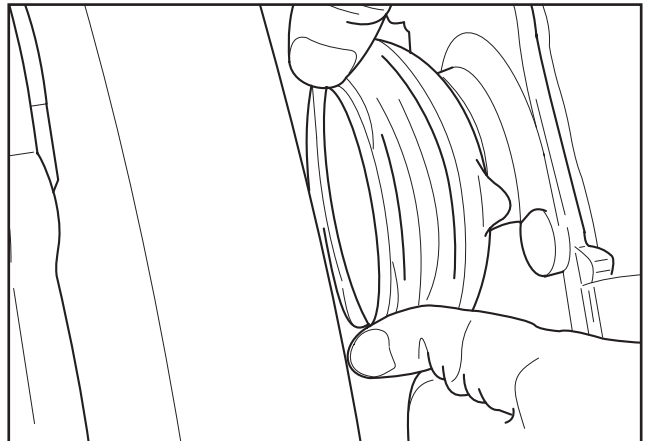

Fig 10.6

Carefully fit the dust excluder into groove on the piston head. Ensure the excluder is correctly seated in the bead groove. (Fig. 10.7)

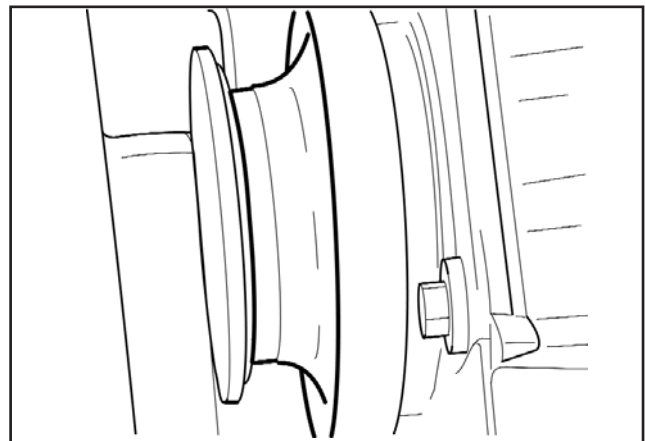

Fig 10.7

10 Piston Head & Dust Excluder Replacement

The next stage is to stretch the dust excluder using 2 fingers. (Fig. 10.8)

With the dust excluder stretched, pull over and fit into the retainer groove in the Brake housing. (Fig. 10.9)

It is essential that the dust excluder is fitted correctly. This is best achieved by rotating the dust excluder and checking for uniform bead fitment into the housing retainer grooves. (Fig. 10.10)

Figure 10.11 shows an incorrectly fitted dust excluder. The bead is not fully located in housing retainer.

Ensure the excluder tab is positioned so that it can be accessed and operated, as shown in Fig. 10.12.

Repeat the operation for the second piston dust excluder.

De-adjust the brake and refit the pads, and where applicable PWWI, set the initial running clearance and test as described in **Section 3 Pad replacement.**

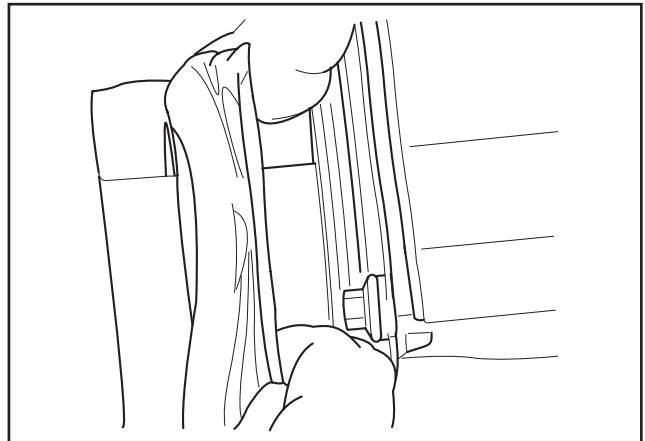

Fig 10.8

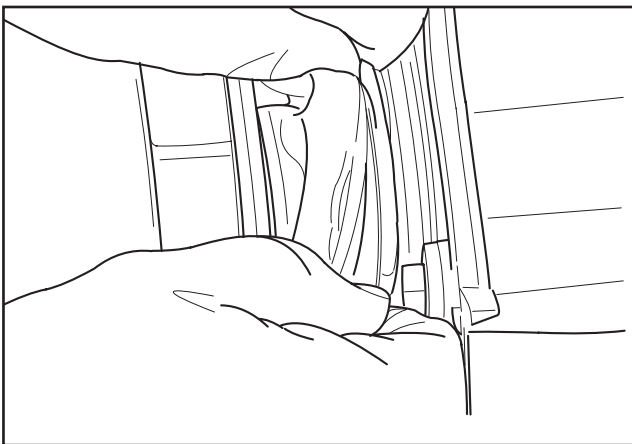

Fig 10.9

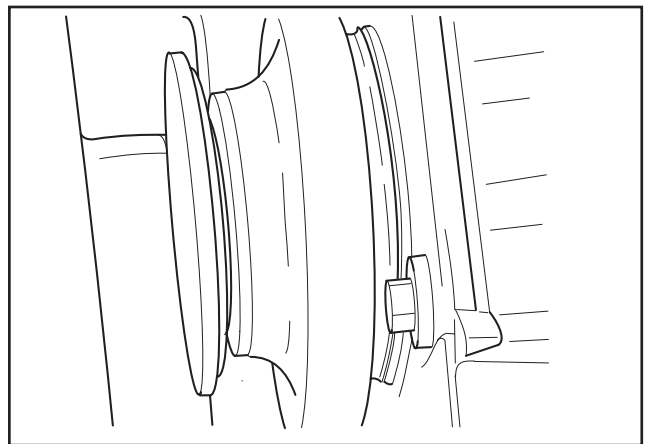

Fig 10.10

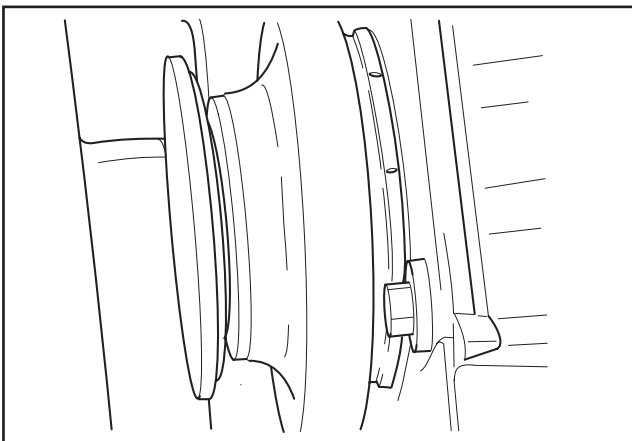

Fig 10.11

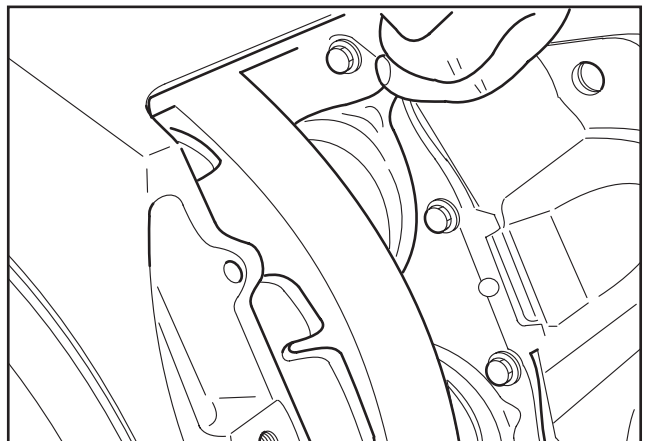

Fig 10.12

Guide Sleeve, Dust Excluder, Retainer & Bush Replacement

11

- pg. 70 Guide sleeve bush & retainer description
- pg. 71 Guide sleeve bush & retainer replacement - Using Meritor CVA Service Tool MST 1060
- pg. 76 Guide sleeve bush & retainer replacement - Using Alternative Tooling
- pg. 80 Removing guide sleeves & guide sleeve dust excluders
- pg. 81 Fitting new guide sleeves & dust excluders
- pg. 82 Fitting new end caps

11 Guide Sleeve, Dust Excluder, Retainer & Bush Replacement

IMPORTANT: The brake assembly number should be noted in order to obtain the correct service kit.

Remove the brake pads as described in **Section 3 Pad replacement.**

Where applicable, remove the CWS as described in **Section 5 CWS replacement.**

Blank off the CWS mounting hole to prevent any dirt ingress into the housing internals.

Remove the Bridge as described in **Section 7 Bridge replacement.**

Remove the housing assembly as described in **Section 8 Housing replacement.**

Transfer the Brake housing to a suitable workbench. Inspect the integrity of the piston excluders. They should be secure and free from any signs of damage. If damaged they should be replaced as described in **Section 10 Piston dust excluder replacement.**

Remove the guide sleeve end caps by carefully drifting out from the guide sleeve bores (Fig. 11.1).

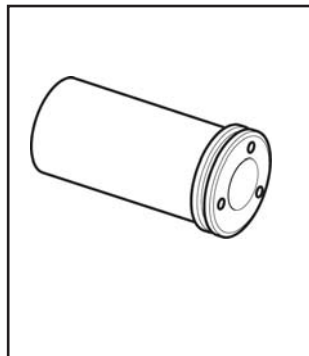
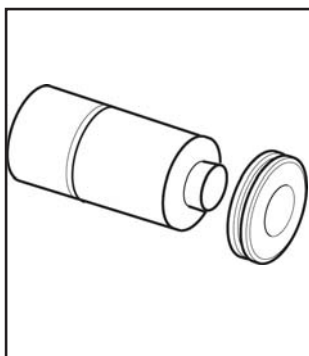
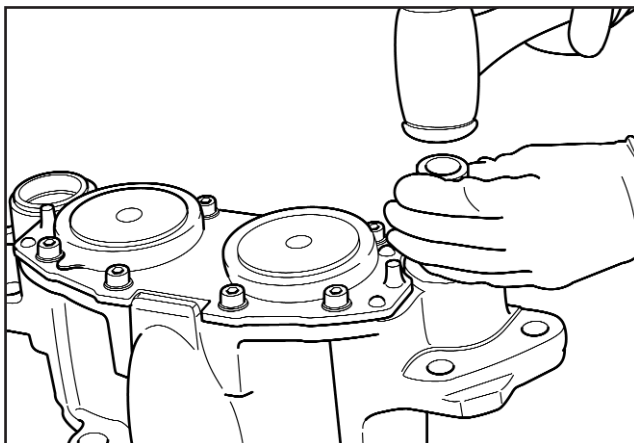

Guide Sleeve Bushes & Retainers Description

There are alternative guide sleeve arrangements that can be found on the Elsa 195/225/250 Disc Brakes.

NOTE: Certain applications use two piece stainless steel guide sleeves as original equipment (Fig. 11.2a). However, the Meritor Aftermarket Service Kits contain the conventional one piece guide sleeves, which are completely interchangeable and the relevant replacement procedures in this section apply.

NOTE: Certain applications use guide sleeves which incorporate three ball bearings in the carrier contact face (Fig. 11.2b). These guide sleeves must only be replaced with guide sleeves of the same type. Ensure the parts provided in the Meritor Service Kit match the guide sleeves being replaced.

Axial & Portal Brakes incorporate a Long and short guide sleeve arrangement.

The Long guide sleeve uses 2 round PTFE lined steel bushes (Fig 11.3).

The short guide sleeve uses a single bronze oval bush (Fig 11.4).

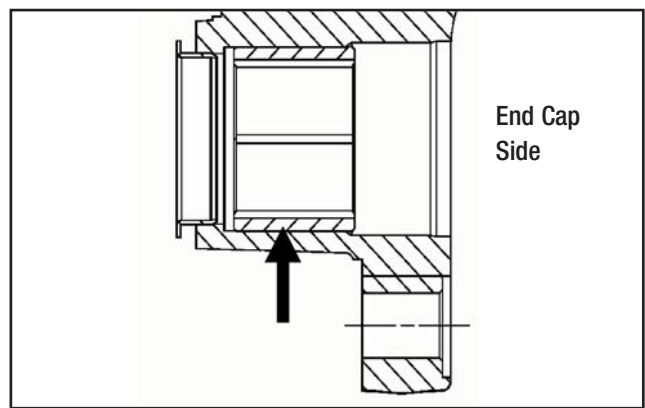
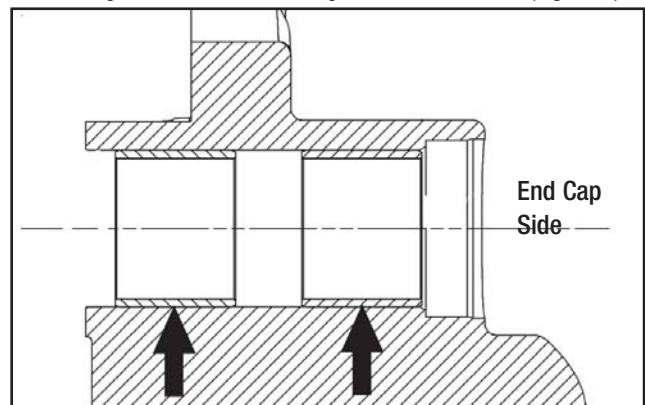

11 Guide Sleeve, Dust Excluder, Retainer & Bush Replacement

Radial Brakes incorporate 2 Long guide sleeves.
One guide sleeve uses 2 round plastic bushes (Fig 11.5)
The second guide sleeve uses 2 bronze oval bushes (Fig 11.6)

NOTE: The process of removing the round plastic guide sleeve bushes from the housing will at the same time remove the dust excluder retainer, which is pressed into the mouth of the housing guide sleeve bore.

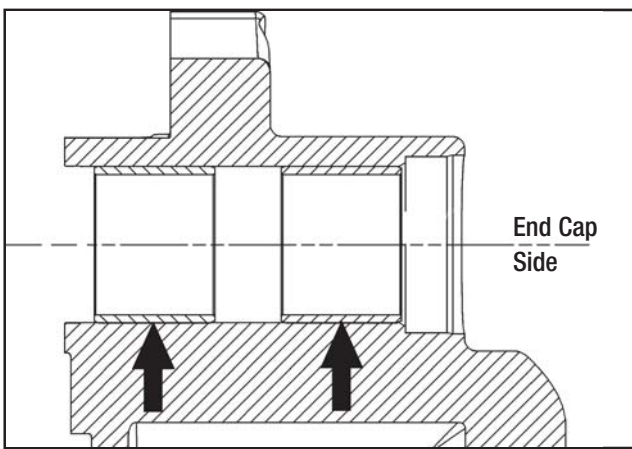

Fig 11.5

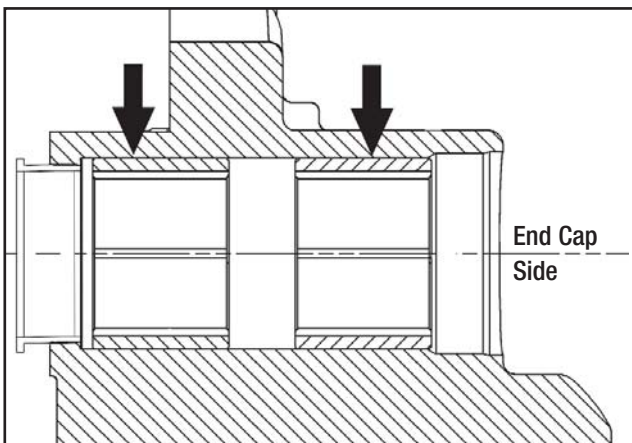

Fig 11.6

IMPORTANT:

This is not true for the removal of the bronze oval bush/bushes,.Due to the presence of a lip (Fig 11.7), the bush/bushes must be removed from the opposite direction to that of the round plastic guide sleeve bushes.

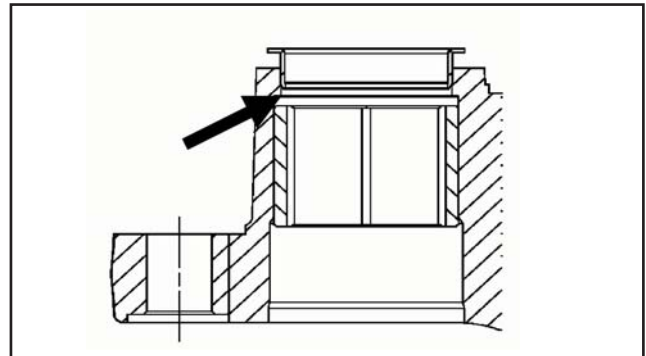

Fig 11.7

NOTE: The recommended method for guide sleeve bush removal and replacement is to use the Meritor CVA Service Tool MST 1060. The use of the Meritor service tool ensures the bushes are fitted to the correct dimensions automatically. If MST 1060 is not available an alternative method for removal and replacement, using alternative tooling, is provided. Follow the appropriate procedures below.

Guide Sleeve Bush & Retainer Replacement - Using Meritor CVA Service Tool MST 1060

Remove the guide sleeve excluder retainers using a suitable lever (Fig 11.8)

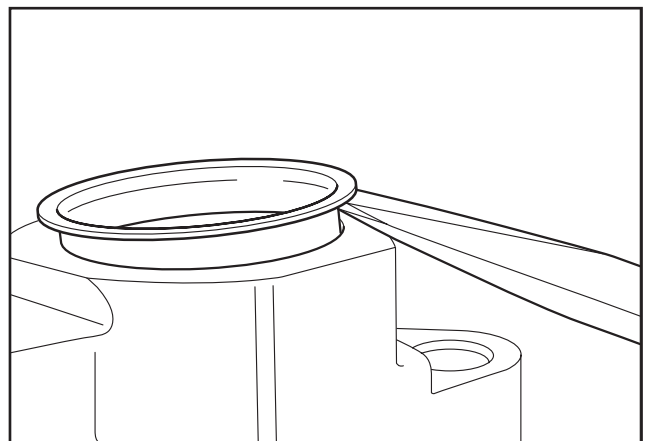

Fig 11.8

11 Guide Sleeve, Dust Excluder, Retainer & Bush Replacement

Removing Guide Sleeve Round Bushes

To remove the round bushes. Using the arbor marked A & B from the Meritor Service Tool MST 1060, locate the end of the arbor marked A into the guide sleeve bore, from the tappet side, and assemble the remaining tool components, using the slotted cup. (Fig 11.9).

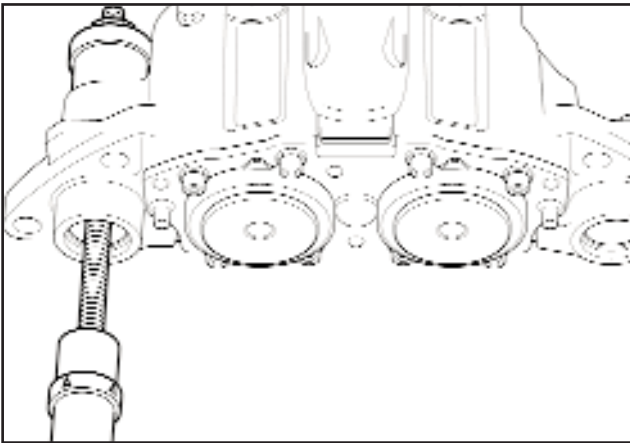

Fig 11.9

Ensure slot in the cup is in a horizontal position relative to the brake housing (Fig. 11.10) to ensure correct location due to the casting split line.

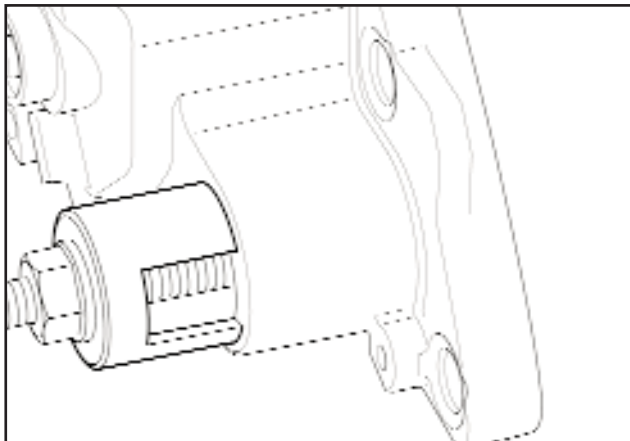

Fig 11.10

Carefully wind down the nut against the arbor to push out the first bush (Fig. 11.11). Remove the slotted cup and first bush from the service tool assembly.

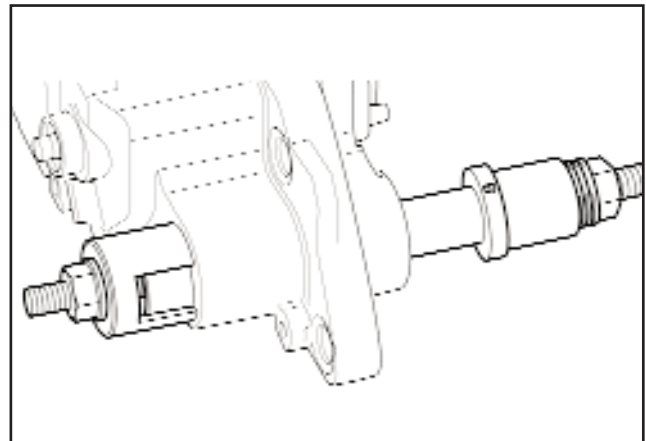

Fig 11.11

Refit the slotted cup, again with the slot in a horizontal position. Continue to wind down the nut against the arbor to remove the second bush.

Remove the service tool components and bush from the brake housing.

Removing Guide Sleeve "Oval" Bush/Bushes

Axial and Radial Brakes

NOTE: It is important to ensure correct alignment of the new bush/bushes. The notches in the bush are aligned in the horizontal plane between the 2 guide sleeve bores. (Fig. 11.12)

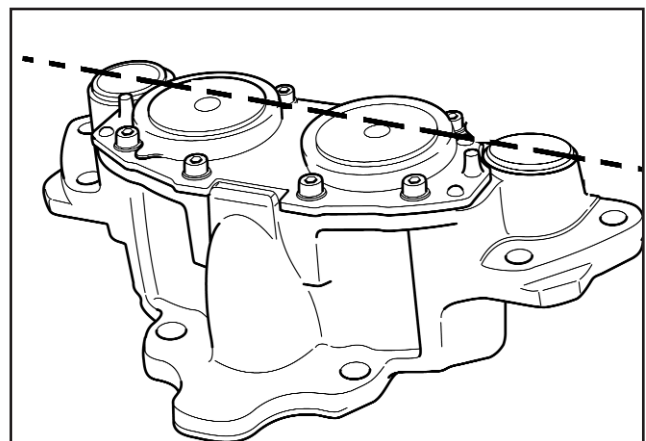

Fig 11.12

11 Guide Sleeve, Dust Excluder, Retainer & Bush Replacement

Before removal, check the alignment of the oval Bush/bushes and mark the housing so that the new bush/bushes can be correctly aligned before fitment. (Fig. 11.13)

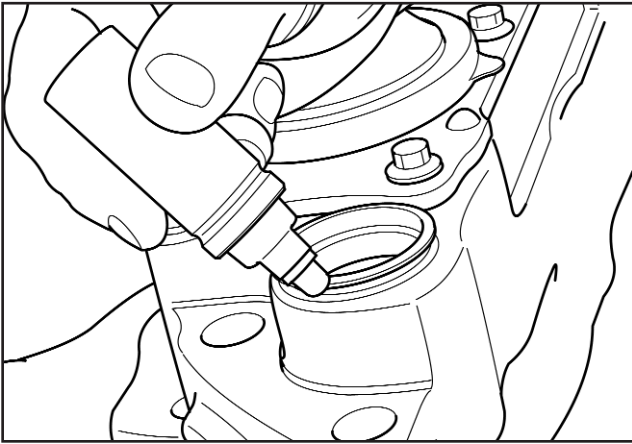

Fig 11.13

Using the arbor marked C & D from the Meritor Service Tool MST 1060, locate the end of the arbor marked C into the guide sleeve bore, from the tappet side, and assemble the remaining tool components, using the slotted cup. (Fig 11.14). Ensure slot in the cup is in a horizontal position relative to the brake housing to ensure correct location (Fig. 11.10).

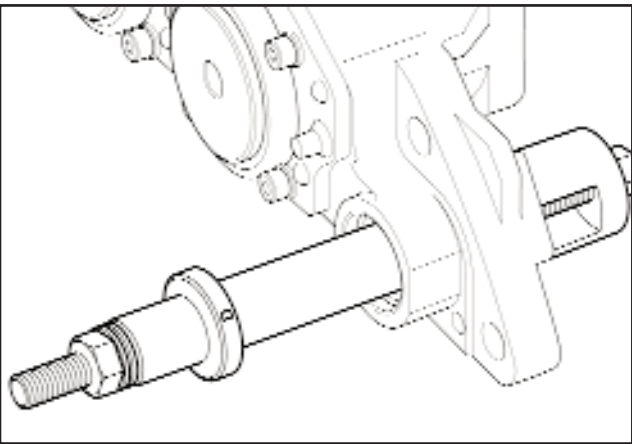

Fig 11.14

Axial Brakes

Carefully wind down the nut against the arbor to push out the bush (Fig. 11.15). Remove the slotted cup and bush from the service tool assembly.

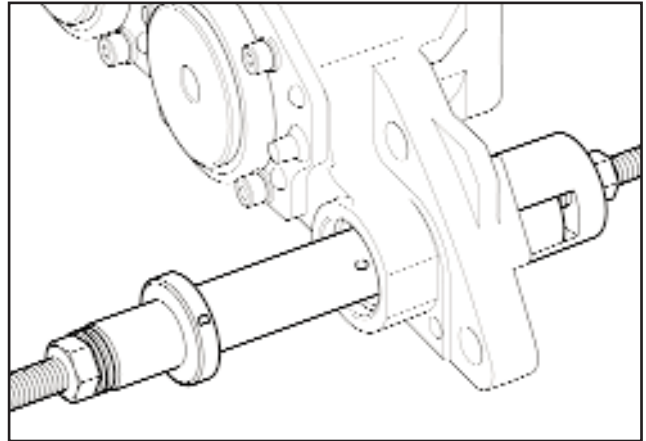

Fig 11.15

Radial Brakes

Carefully wind down the nut against the arbor to push out the first bush. Remove the slotted cup and first bush from the service tool assembly.

Refit the slotted cup, again with the slot in a horizontal position. Continue to wind down the nut against the arbor to remove the second bush.

Remove the service tool components and bush from the brake housing.

NOTE: Clean the guide sleeve bores with a suitable brake cleaner. Examine the condition of the bores for wear corrosion or damage. If there is any doubt in the suitability for further service replace with a new housing assembly.



CAUTION: Ensure any grease removed from the assembly/components, or contaminated cloth, is disposed of in accordance with local environmental regulations.

11 Guide Sleeve, Dust Excluder, Retainer & Bush Replacement

Fitting Guide Sleeve Oval Bush

Axial Brakes

Align the new oval bronze bush with markings made on the housing before removal of the original bush (Fig. 11.16).

NOTE: The bush must be fitted from the actuator side of the housing.

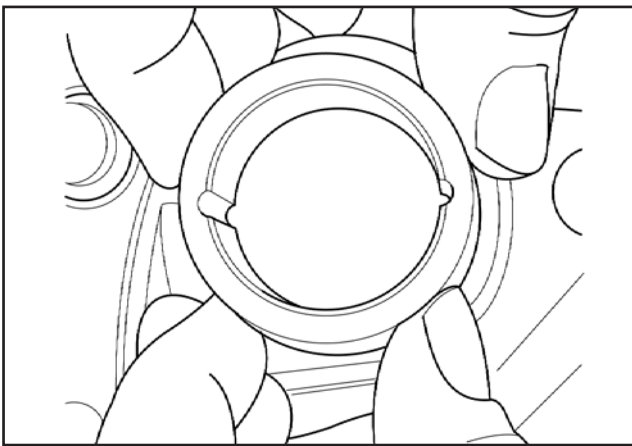

Fig 11.16

Using the arbor marked C & D from the Meritor Service Tool MST 1060, fit the end of the arbor marked C in to the bush, Using the end stop and remaining parts of Meritor CVA. Service Tool MST 1060, wind down the nut against the arbor to push the oval bush into the guide sleeve bore until it contacts the end stop (Fig. 11.17).

This will ensure the bush is fitted to the correct dimension.



CAUTION: Do not apply excessive force when pushing the bush into the bore as this may result in damage to the bush.

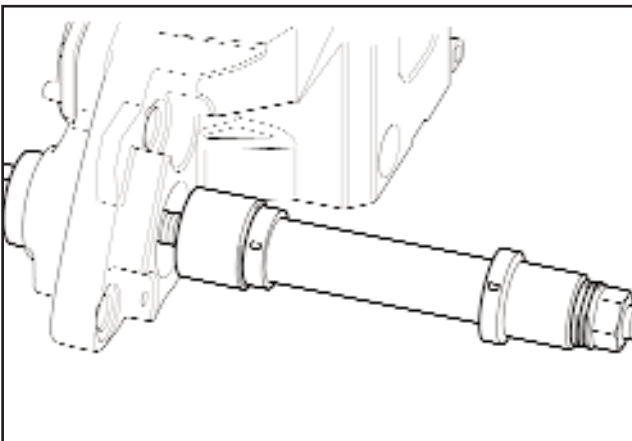

Fig 11.17

Radial Brakes

NOTE: Both bushes must be fitted from the actuator side of the housing.

Place one of the new oval bushes on the housing and ensure the notches on the bush edge align with the marks made on the housing before removal of the original bushes (Fig 11.16).

Using the arbor marked C & D from the Meritor Service Tool MST 1060, fit the end of the arbor marked C in to the bush, Using the end stop and remaining parts of Meritor CVA. Service Tool MST 1060, wind down the nut against the arbor to push the oval bush into the guide sleeve bore until it contacts the end stop (Fig. 11.17).

This will ensure the bush is fitted to the correct dimension. Remove the service tool components.

Place the second bush on to the housing, again ensure the notches on the bush edge align with the marks on the guide sleeve turret (Fig 11.16).

Using the arbor marked C & D from the Meritor Service Tool MST 1060, fit the end of the arbor marked D in to the bush, Using the end stop and remaining parts of Meritor CVA. Service Tool MST 1060, wind down the nut against the arbor to push the oval bush into the guide sleeve bore until it contacts the end stop (Fig. 11.18).

This will ensure the bush is fitted to the correct dimension.

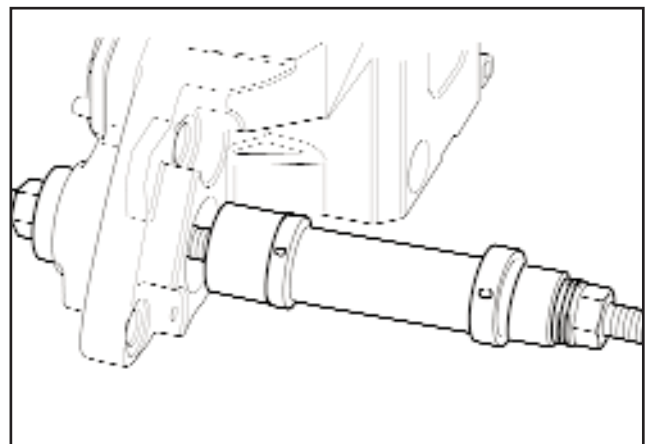

Fig 11.18



CAUTION: Do not apply excessive force when pushing the bushes into the bore as this may result in damage to the bushes.

11 Guide Sleeve, Dust Excluder, Retainer & Bush Replacement

Fitting Guide Sleeve Round Bushes

Axial & Radial Brakes

NOTE: Both bushes must be fitted from the actuator side of the housing.

Using the arbor marked A & B from the Meritor Service Tool MST 1060, fit the end of the arbor marked A in to one of the new bushes. Locate the arbor and bush in the guide sleeve bore. Using the end stop and remaining parts of Meritor CVA. Service Tool MST 1060, wind down the nut against the arbor to push the bush into the guide sleeve bore until it contacts the end stop (Fig. 11.19).

This will ensure the bush is fitted to the correct dimension.

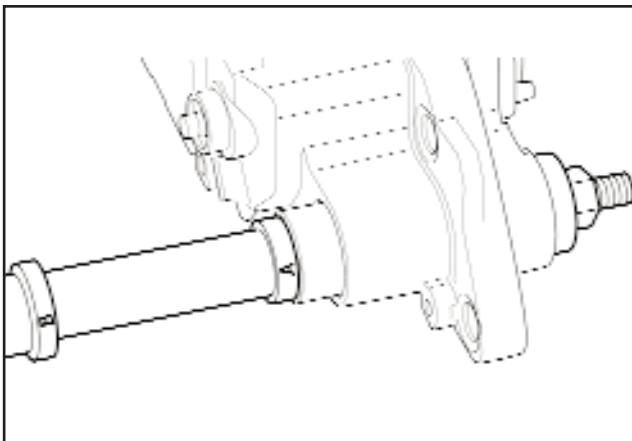

Fig 11.19

Remove the service tool components.

Fit the end of the arbor marked B in to the second new bush. Locate the arbor and bush in the guide sleeve bore. Using the end stop and remaining parts of Meritor CVA. Service Tool MST 1060, wind down the nut against the arbor to push the bush into the guide sleeve bore until it contacts the end stop (Fig. 11.20). This will ensure the bush is fitted to the correct dimension. Remove the service tool components.

Fitting New Dust Excluder Retainers

Using Meritor CVA. Service tool MST1060, place a new retainer onto the end stop from the service tool (Fig. 11.21). Place retainer onto the housing and using the slotted cup and remaining service tool components, carefully wind down the nut against the end stop to push the new retainer in to the guide sleeve bore (Fig. 11.22).



CAUTION: Do not apply excessive force when pulling the retainers into the bore as this may result in damage to the bush or retainer

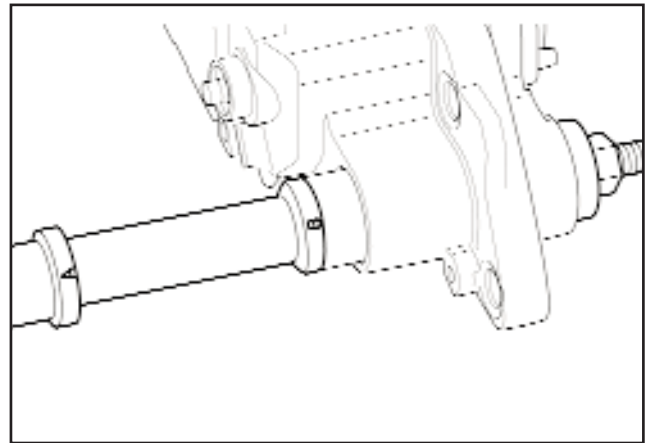

Fig 11.20

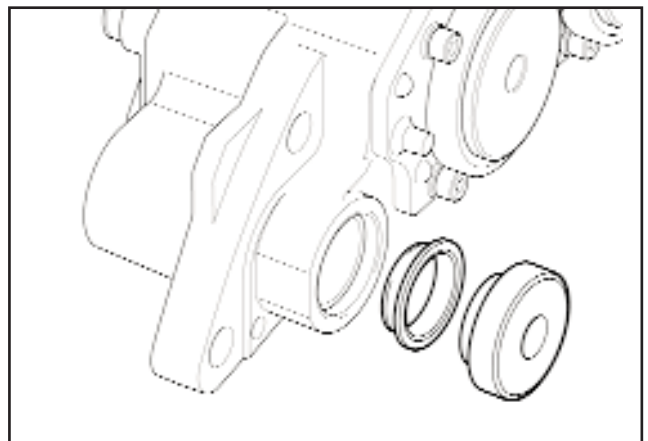

Fig 11.21

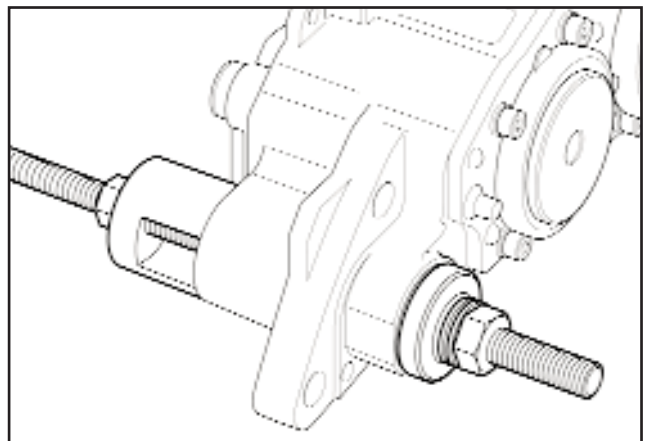

Fig 11.22

11 Guide Sleeve, Dust Excluder, Retainer & Bush Replacement

Guide Sleeve Bush & Retainer Replacement - Using Alternative Tooling

Remove the guide sleeve excluder retainers using a suitable lever (Fig 11.23)

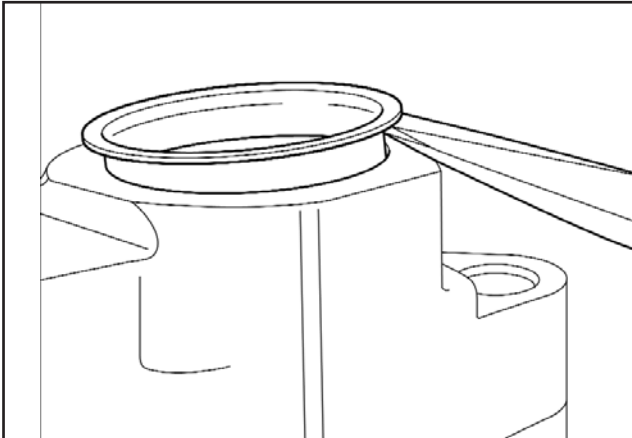

Fig 11.23

Removing Guide Sleeve Round Bushes

To remove the round bushes. Using a suitable arbor, press or drift out the bushes from the housing (Fig 11.24)

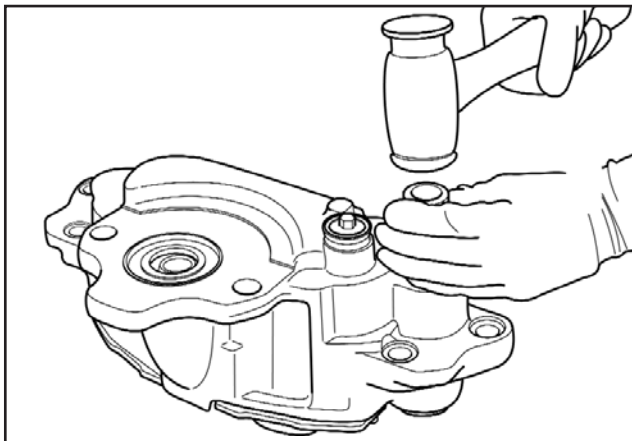

Fig 11.24

Removing Guide Sleeve "Oval" Bush/Bushes

NOTE: It is important to ensure correct alignment of the new bush/bushes. The notches in the bush are aligned in the horizontal plane between the 2 guide sleeve bores. (Fig. 11.25)

Before removal, check the alignment of the oval Bush/bushes and mark the housing so that the new bush/bushes can be correctly aligned before fitment. (Fig. 11.26)

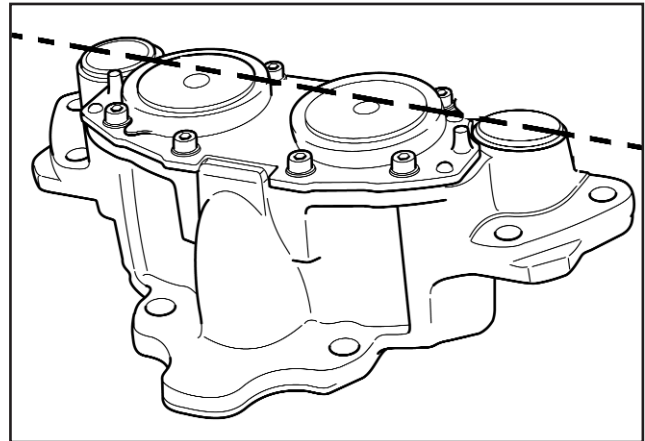

Fig 11.25

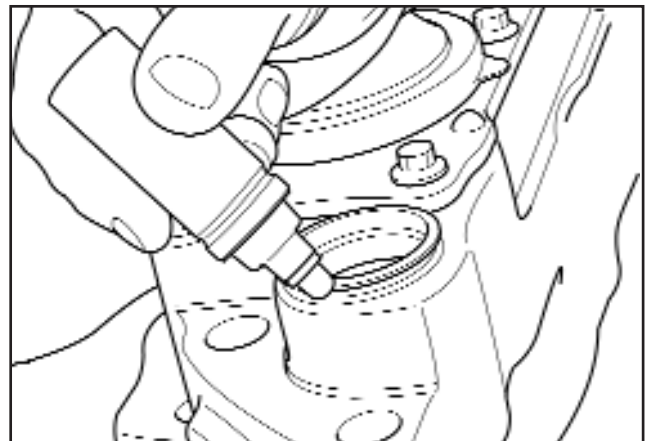

Fig 11.26

Using a suitable arbor, press or drift out the bush from the housing (Fig 11.27).

NOTE: The oval bush/bushes must be pushed out from the tappet side of the bore, in the direction of the end cap side of the bore as shown in Fig 11.27.

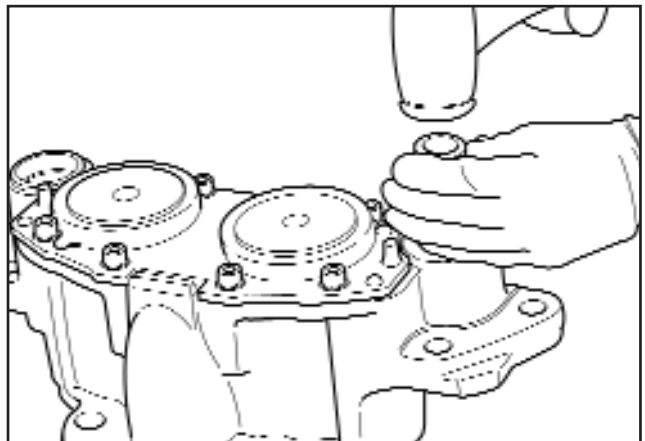

Fig 11.27

11 Guide Sleeve, Dust Excluder, Retainer & Bush Replacement

NOTE: Clean the guide sleeve bores with a suitable brake cleaner. Examine the condition of the bores for wear corrosion or damage. If there is any doubt in the suitability for further service replace with a new housing assembly.



CAUTION: Ensure any grease removed from the assembly/components, or contaminated cloth, is disposed of in accordance with local environmental regulations.

Fitting Guide Sleeve Oval Bush

Axial Brakes

Align the new oval bronze bush with markings made on the housing before removal of the original bush (Fig. 11.28).

NOTE: The bush must be assembled from the actuator side of the housing.

Using a suitable arbor with a length of threaded rod and suitable nuts and washers, insert new bush into the housing bore (Fig. 11.29).

Pull the oval bush into the guide sleeve bore to a depth between 9.2 to 9.6 mm from the end of the guide sleeve excluder retainer side of the bore (Figs 11.30 & 11.31).

The bush must be fitted from the actuator side of the housing. Do not drift in the bush as this may damage the edge and prevent the fitment of the guide sleeve.

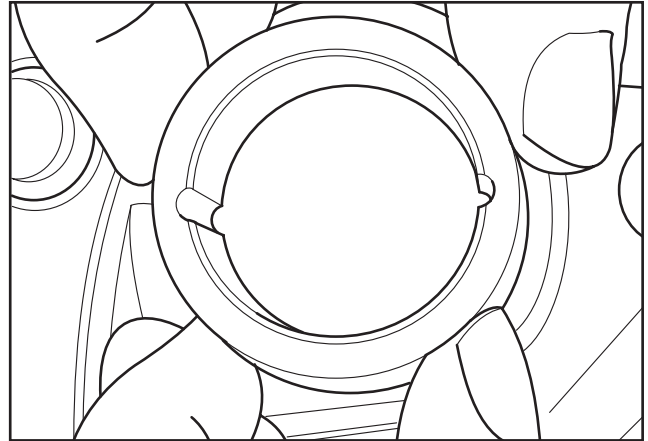

Fig 11.28

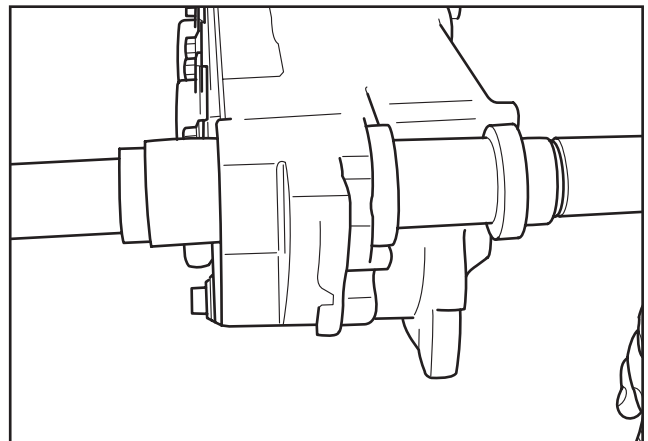

Fig 11.29

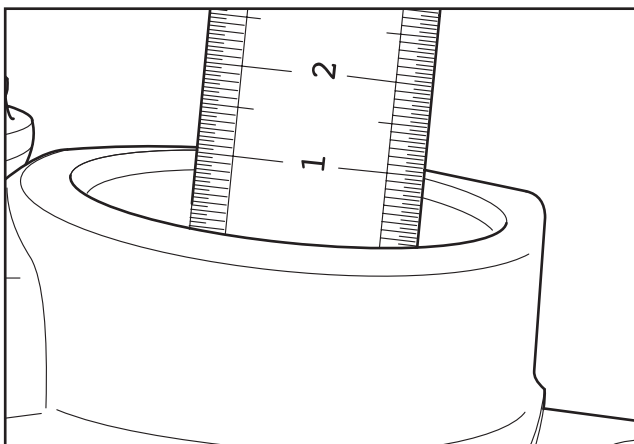

Fig 11.30

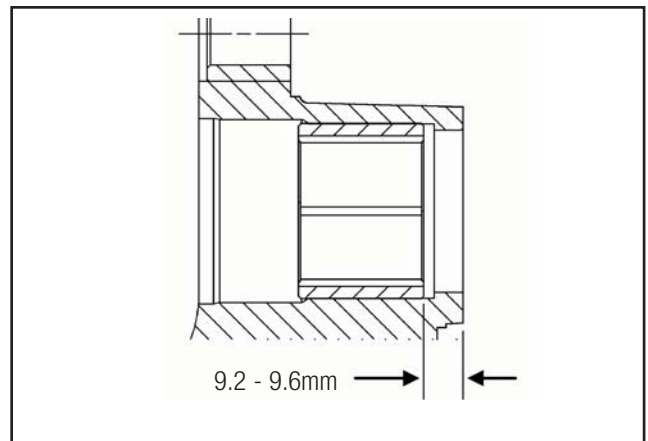

Fig 11.31

11 Guide Sleeve, Dust Excluder, Retainer & Bush Replacement

Radial Brakes

NOTE: Both bushes must be fitted from the actuator side of the housing (Figs 11.33 & 11.35). Do not drift in the bushes as this may damage the edge and prevent the fitment of the guide sleeve.

Place one of the new oval bushes on the housing and ensure the notches on the bush edge align with the marks made on the housing before removal of the original bushes (Fig 11.32). Using a suitable arbor with a length of threaded rod and suitable nuts and washers, pull the bush into the guide sleeve bore to a depth between 9.2 and 9.6mm from the end face of the housing (dust excluder retainer side of the bore) (Fig 11.33).

Place the second bush on to the housing, again ensure the notches on the bush edge align with the marks on the guide sleeve turret (Fig 11.34).

Using the same arbor and associated parts, pull the bush into the guide sleeve bore.

The correct position of the bush can be confirmed by measuring the distance from the same end face of the housing (dust excluder retainer side of the bore) to the bottom edge of the second bush. This should be 83.8 - 84.2mm, (Fig 11.35)

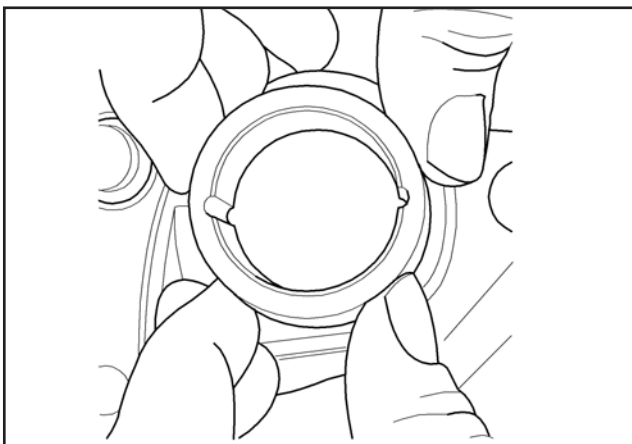

Fig 11.32

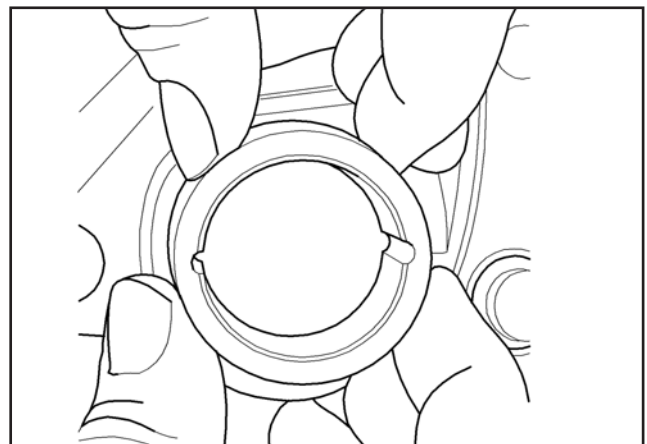

Fig 11.34

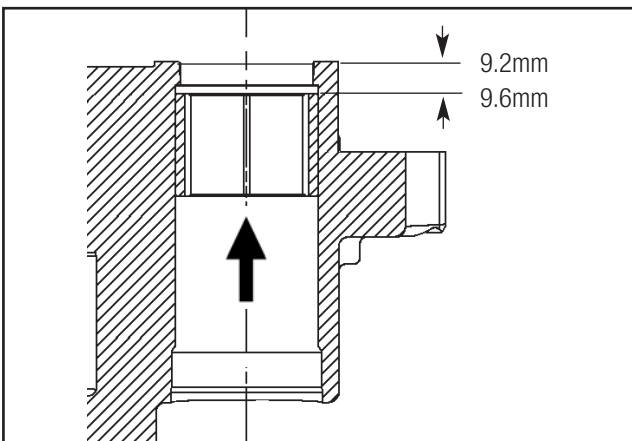

Fig 11.33

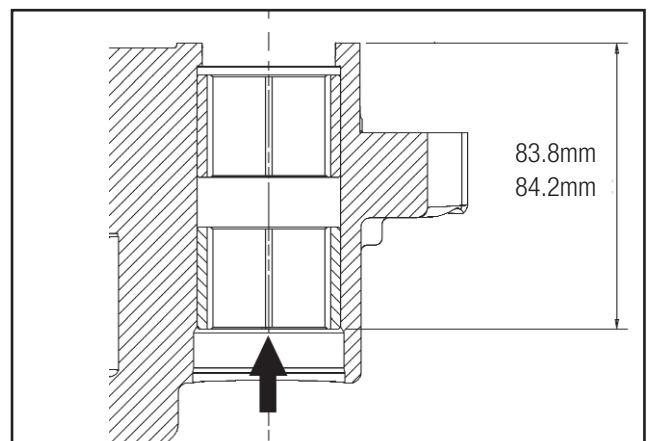

Fig 11.35

11 Guide Sleeve, Dust Excluder, Retainer & Bush Replacement

Fitting Guide Sleeve Round Bushes

Axial & Radial Brakes

Using a suitable arbor with a length of threaded rod and suitable nuts and washers, Insert into the housing bore from the guide sleeve excluder/retainer side of the bore (Fig 11.36).

Pull the bush into the guide sleeve bore to a depth of 7.2 to 7.6 mm measured from the end face of the housing (dust excluder/retainer side of the bore)(Fig 11.37).

 **CAUTION:** Do not apply excessive force when pulling the bush/s into the housing as this may result in damage to the bush/s.

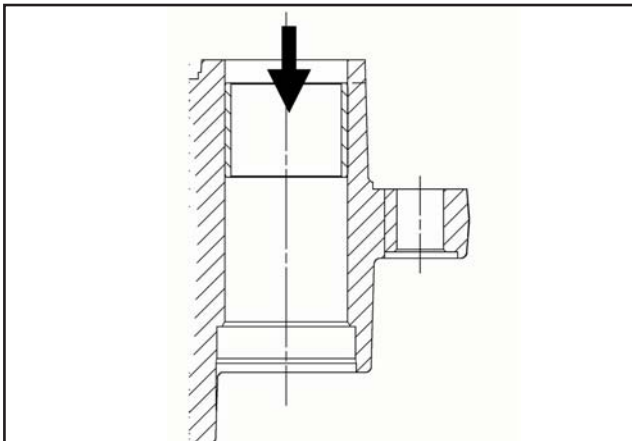

Fig 11.36

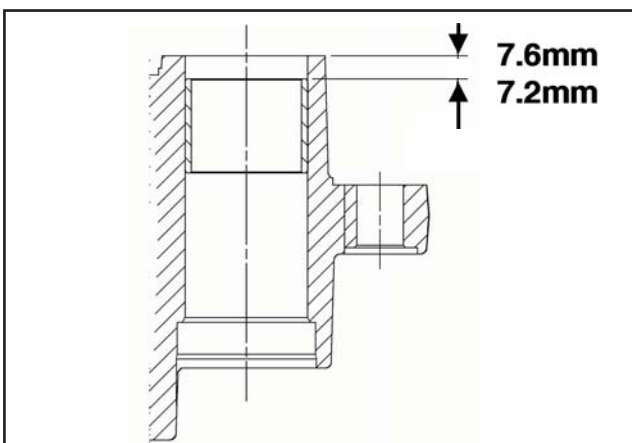

Fig 11.37

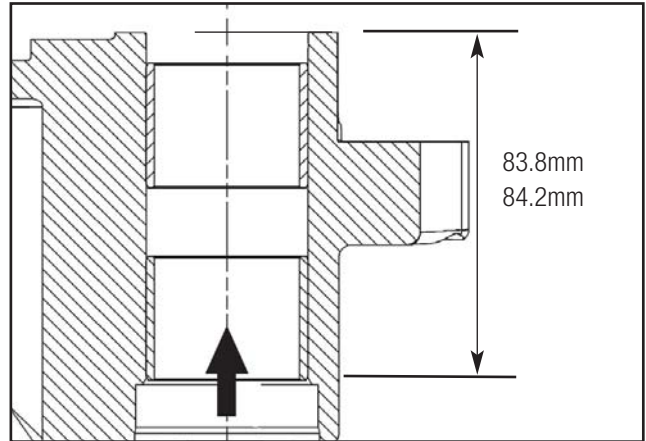



Fig 11.38

Repeat this process for the second bush, but insert the bush from the end cap side of the bore.

The correct position of the bush can be confirmed by measuring the distance from the same end face of the housing (dust excluder/retainer side of the bore) to the bottom of the second bush. This should be 83.8 - 84.2mm, (Fig 11.38).

Fitting New Dust Excluder Retainers

Always use Using a suitable arbor (Fig. 11.39) with a length of threaded rod and suitable nuts and washers, to fit the dust excluder retainers. .

 **CAUTION:** Do not attempt to fit the retainers with a hammer or mallet. This could result in damage to the retainer, incorrect location in the housing bore resulting in incorrect guide sleeve excluder location.

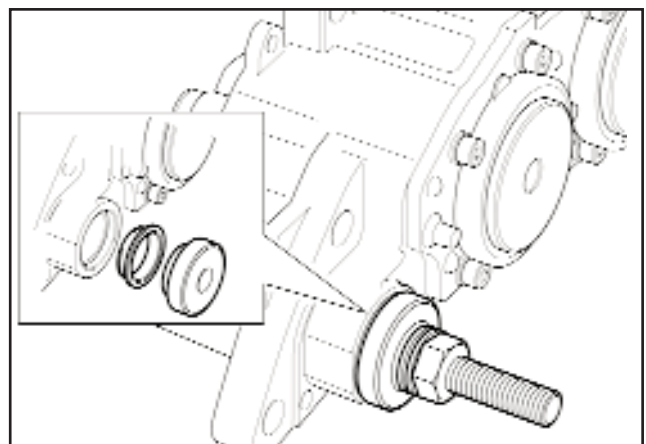

Fig 11.39

11 Guide Sleeve, Dust Excluder, Retainer & Bush Replacement

Fitting Guide Sleeve Retainer - Oval Bush

Place retainer onto the housing and using the arbor and associated parts, draw the retainer into the guide sleeve bore until the flat face of the retainer is between 4.65 to 5.15mm from the end of the guide sleeve bore (Fig 11.40).

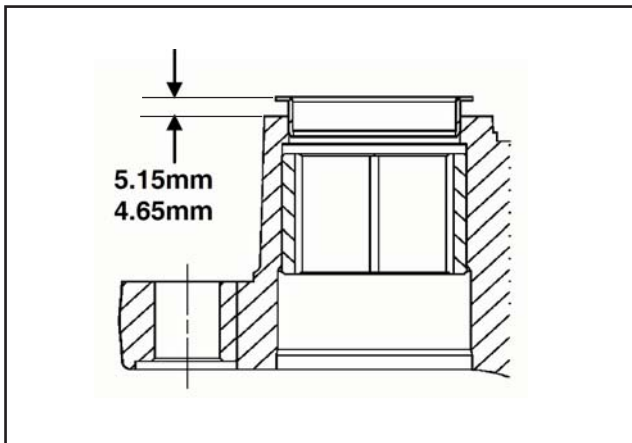

Fig 11.40

Fitting Guide Sleeve Retainer - Round Bush

Place retainer onto the housing and using the arbor and associated parts, draw the retainer into the guide sleeve bore until the flat face of the retainer is between 4.65 to 5.15mm from the end of the guide sleeve bore (Fig 11.41).



CAUTION:

Do not apply excessive force when pulling the retainers into the bore as this may result in damage to the bush or retainer.

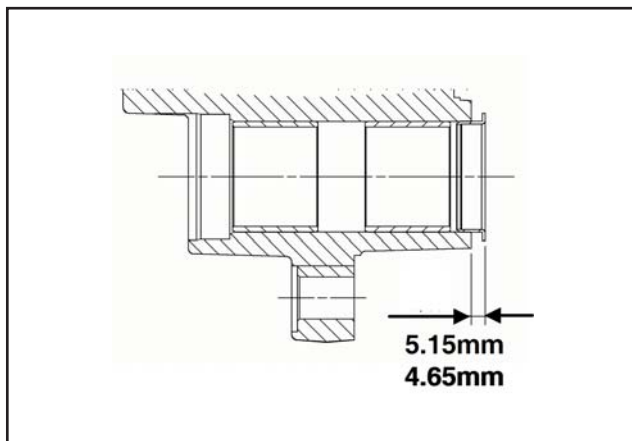

Fig 11.41

Removing Guide Sleeves & Dust Excluders

Carefully detach the guide sleeve dust excluders from their location on the carrier and slide off the guide sleeves (Fig. 11.42)

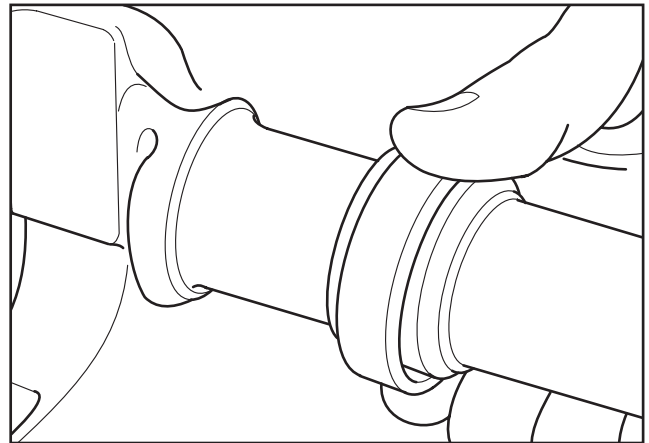

Fig 11.42

NOTE: It is possible that the guide sleeve dust excluder remained attached to the Brake housing retainers and is therefore removed with the housing.

Record the position, where appropriate, of the LONG and SHORT or LARGER and SMALLER diameter guide sleeves on the carrier to ensure the new guide sleeves are located correctly on assembly.

Remove the guide sleeve screws retaining the guide sleeves to the carrier (Fig. 11.43). If necessary carefully release the guide sleeves from their location on the carrier using a rubber or soft metal hammer.

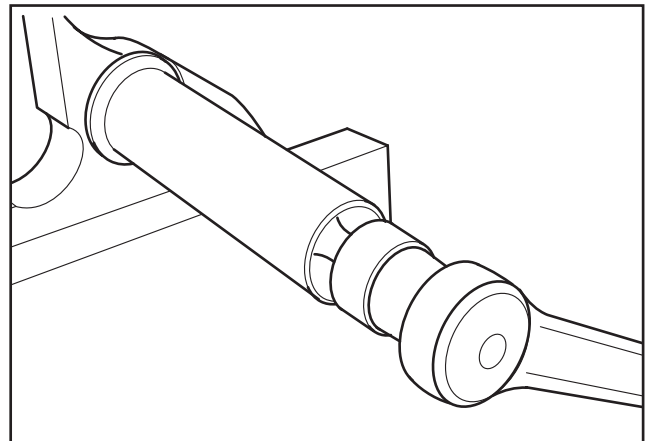

Fig 11.43

11 Guide Sleeve, Dust Excluder, Retainer & Bush Replacement

Clean the guide sleeve contact areas and threaded holes in the carrier. Check for wear. If in doubt in the suitability for further service replace the carrier as described in **Section 9** Carrier replacement.

NOTE: If the guide sleeves incorporate ball bearings there should be three ball bearings in the carrier contact face and three matching indentations on the carrier. These indentations are expected and should not be considered as damage to the carrier.

Fitting new Guide Sleeves

NOTE: It is important to use the correct guide sleeves for the brake assembly. Ensure the parts provided in the Meritor Service Kit are compatible with the guide sleeves being replaced.

NOTE: Certain brake applications may be fitted with standard guide sleeves. If retrofitting brakes with guide sleeves which incorporate ball bearings in the carrier contact face, indentations will not be present in the carrier prior to assembly.

NOTE: Before fitting guide sleeves which incorporate ball bearings ensure the three ball bearings are present in the carrier contact face of the guide sleeve.

NOTE: If servicing a brake assembly which has indentations present in the carrier contact face, it is not critical to align the guide sleeve ball bearings with the indentations.

Locate the new guide sleeves in the correct position on the carrier and secure with the new guide sleeve screws. If fitting guide sleeves which incorporate ball bearings, lightly grease the underside of the screw heads before fitting.

NOTE: It is important to apply grease to the underside of the screw heads to achieve the correct torque and angle tightening method.

NOTE: Only use the grease supplied with replacement components/kits, or that specified by the vehicle manufacturer. Under no circumstance should any other type of grease be used.

NOTE: Ensure the LONG and SHORT or LARGER and SMALLER diameter guide sleeves are in the correct configuration on the carrier.

Tighten the new guide pin screws to the correct torque, as as specified in **section 14 Servicing and Specifications**.

Lightly lubricate the new guide sleeves and the guide sleeve dust excluder, on the inside only.

NOTE: Only use the grease supplied with replacement components/kits, or that specified by the vehicle manufacturer. Under no circumstance should any other type of grease be used.

Fitting new Dust Excluders

Slide the dust excluders over the guide sleeves, ensure to locate the excluder bead in the retainer groove on the carrier. (Figs. 11.44 & 11.45).

Apply grease to the guide sleeve bores in the housing.

NOTE: Only use the grease supplied with replacement components/kits, or that specified by the vehicle manufacturer. Under no circumstance should any other type of grease be used.

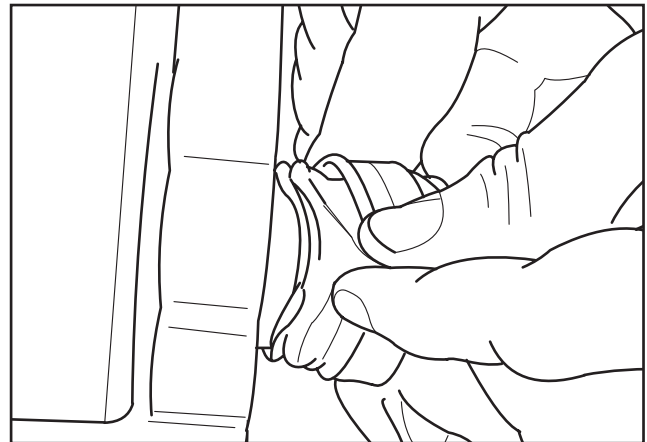

Fig 11.44

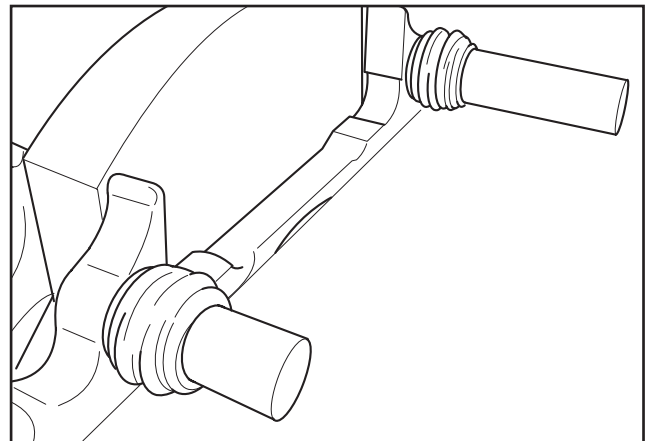

Fig 11.45

11 Guide Sleeve, Dust Excluder, Retainer & Bush Replacement

Carefully slide the housing assembly into position on the guide sleeves secured to the carrier (Fig. 11.46) Do not forget the visual wear indicator and spring where applicable.

NOTE: Take care not to damage the guide sleeve dust excluders when locating the housing on to the carrier.

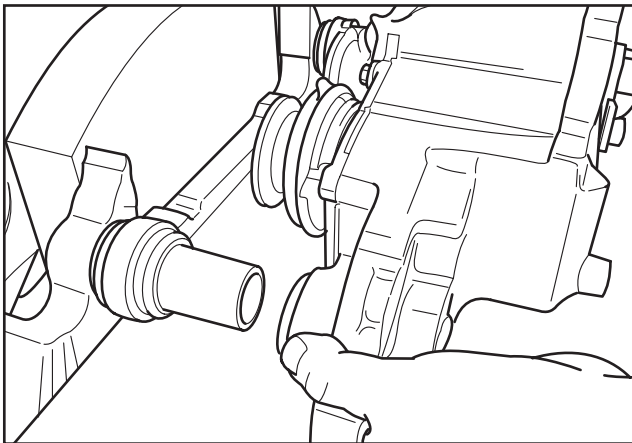

Fig 11.46

Locate the guide sleeve dust excluder beads in to the grooves on the housing retainers (Fig 11.47)
Ensure the dust excluders are located correctly on both carrier and housing retainers (Fig 11.48)

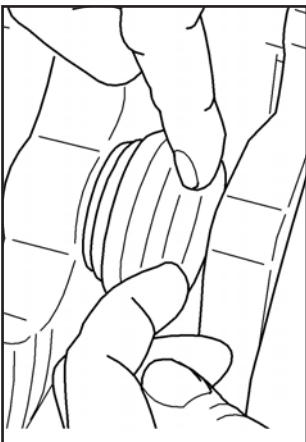

Fig 11.47

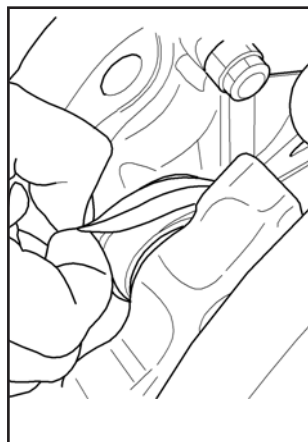

Fig 11.48

Slide the housing backwards and forwards several times to check the smooth movement of the guide sleeves.

NOTE: Care must be taken when sliding the housing on the guide sleeves by hand. Too much force could result in damage to the guide sleeve dust excluders



CAUTION: Take care not to trap fingers whilst checking the smooth movement of the guide sleeves.

Fitting new End Caps

There are variations in brake design currently in service. Follow the appropriate procedure below to fit the new end caps.

Axial 195/225/250 - Early Design

Using a copper faced mallet and suitable arbor, carefully tap one of the new end caps into the housing until it retains itself (Fig 11.49) Repeat for the second end cap. Using the arbor tap the end caps in until they meet the dimensions 1.75mm - 2,25mm for the short guide sleeve (Fig. 11.50) and 6.4mm - 5.8mm for the long guide sleeve (Fig. 11.51) .

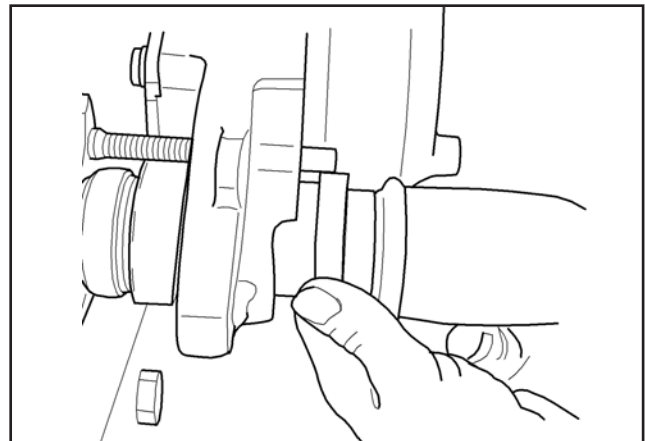

Fig 11.49

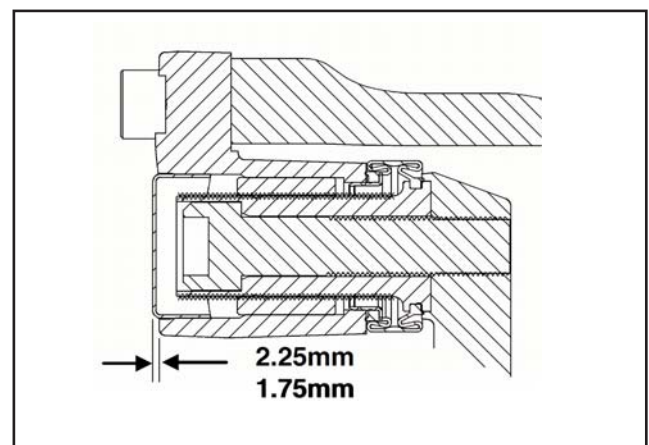

Fig 11.50

11 Guide Sleeve, Dust Excluder, Retainer & Bush Replacement

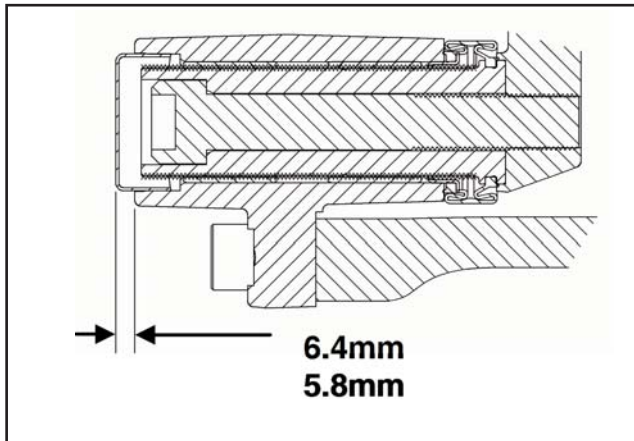

Fig 11.51

NOTE: The end caps for long and short pins must be fitted to the different dimension as shown in Fig 11.50 for short pin & Fig 11.51 for long pin. The dimensions must be checked to ensure that they do not exceed the stated maximum figures.

Axial 195/225/250 - Later Design

Radial 225 - All Levels

Using a copper faced mallet and suitable arbor, carefully tap one of the new end caps into the housing until it retains itself (Fig 11.49)

Repeat for the second end cap.

Using the arbor, tap the end caps in until they meet the dimension 1.75mm - 2.25mm (Fig. 11.50).

NOTE: The dimensions must be checked to ensure that they do not exceed the stated maximum figures.

When the end caps have been correctly fitted, check again the free movement of the housing assembly on the guide sleeves. Slide the housing backwards and forwards several times to check the smooth movement of the housing on the guide sleeves. Slide the housing to check the location of the dust excluders (Fig. 11.52).

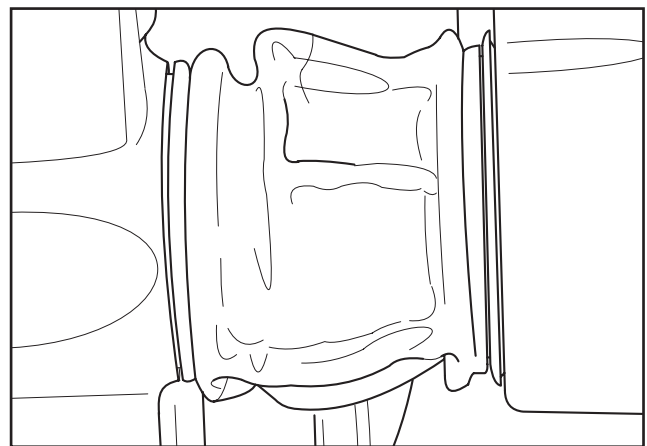

Fig 11.52

NOTE: Care must be taken when sliding the housing on the guide pins by hand. Too much force could result in damage to the guide pin dust excluders

Refit the bridge as described in **Section 7 Bridge replacement.**



CAUTION: Always use new bridge screws. Once removed bridge screws should not be re-used.

Remove the blanking protection from the CWS aperture and refit the CWS as described in **Section 5 CWS replacement.**

Refit the air actuator as described in **Section 6 Brake replacement.**

Refit the pads and where applicable the PWWI, set the initial running clearance and test as described in **Section 3 Pad replacement.**

11 Guide Sleeve, Dust Excluder, Retainer & Bush Replacement

Carrier Dowel Bush Replacement

12

Bush

pg. 86 Carrier Dowel Bush Removal

pg. 86 Carrier Dowel Bush Fitment

12 Carrier Dowel Bush Replacement

Remove the carrier as described in Section 9 Carrier Replacement. Transfer the carrier to a suitable work bench and secure in a vice.. Ensure the dowel bushes in the carrier are positioned at the top (Fig 12.1).

Removal of the Dowel Bushes

Using a suitable pair of grips, grip the dowel bush until the split in the dowel bush is closed (Fig. 12.2).

Remove the dowel bush by turning the bush clockwise and anticlockwise to ease the bush out of the carrier (Fig. 12.3).

Repeat the procedure above for the second dowel bush.

Cleaning and Inspection.

Clean the carrier paying particular attention to the dowel bush counter bore and mounting face ensuring they are free from corrosion and debris.

If there is any doubt in the suitability of the carrier for continued service it must be replaced with a new Meritor carrier.

Fitting the Dowel Bushes.

Using a suitable pair of grips, grip one of the dowel bushes at one end so the bush extends past the jaws of the grips, as shown in Fig. 12.4.

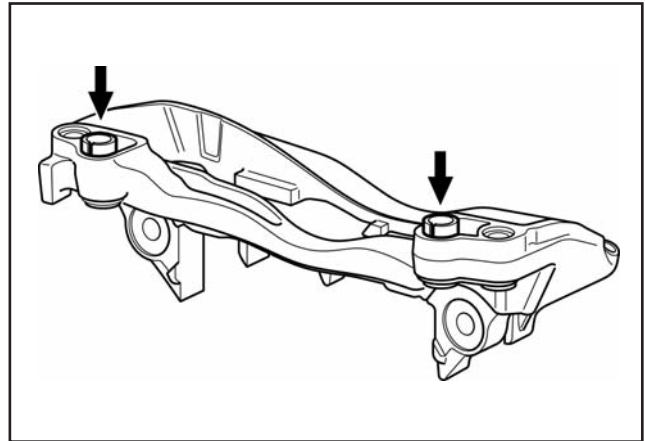

Fig 12.1

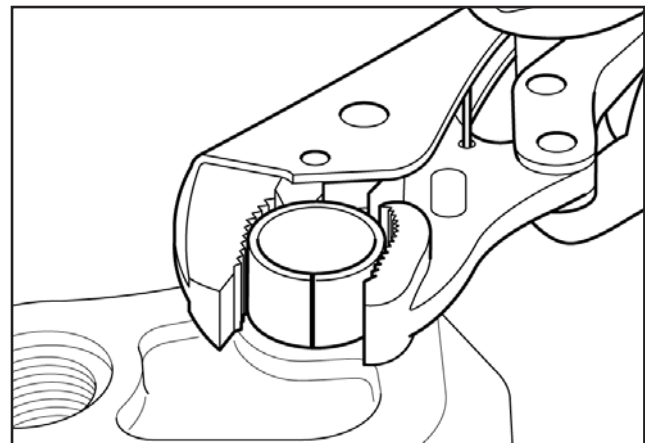

Fig 12.2

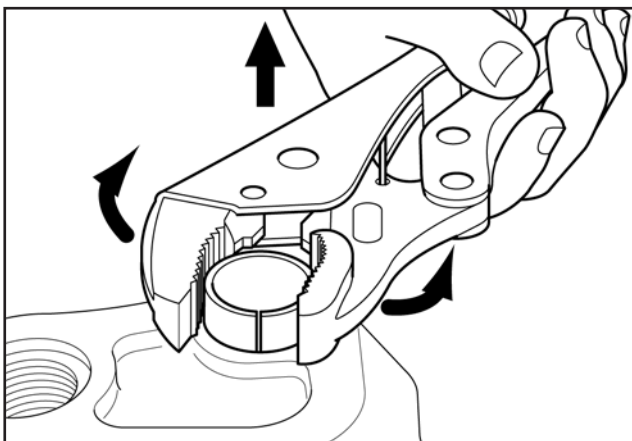

Fig 12.3

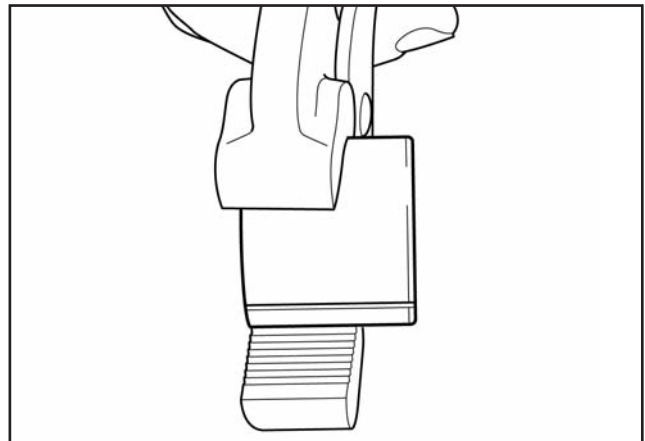

Fig 12.4

12 Carrier Dowel Bush Replacement

Adjust the grips until the split in the bush is closed (Fig. 12.5).



CAUTION: Ensure the dowel bush is aligned correctly with the counter bore in the carrier. Do not use excessive force when tapping the dowel bush into the counter bore as this may result in damage to the dowel bush.

Align the dowel bush with the counter bore in the carrier and using a soft faced mallet carefully tap the bush into the counter bore until the bush abuts the shoulder in the counter bore (Fig. 12.6).

Repeat the procedure above for the second dowel bush.

When the dowel bushes have been fitted check that they have not been damaged during the fitting process which may prevent correct location of the carrier on the axle.

Refit the carrier, as described in Section 9 Carrier replacement.

Refit the housing assembly, as described in Section 8 Housing Replacement

Using the new bridge bolts provided, refit the bridge as described in **Section 7 Bridge replacement.**



CAUTION: Always use new bridge screws. Once removed bridge screws must not be re-used.

Where applicable refit the CWS .

NOTE: There are alternative design continuous wear sensors in service. For removal/replacement, refer to Section 5 for the standard sensor which incorporates an integral wiring lead, and refer to Supplement 2 for the cartridge design sensor.

Refit the air actuator as described in **Section 6 Brake replacement.**

Refit the pads and where applicable the PWVI, set the initial running clearance and test as described in **Section 3 Pad replacement.**

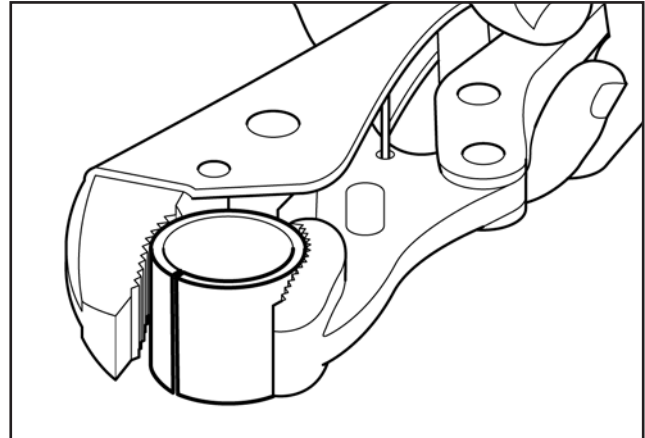

Fig 12.5

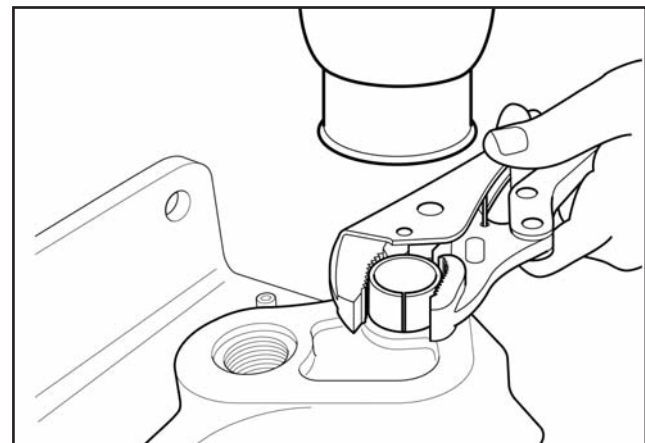

Fig 12.6

12 Carrier Dowel Bush Replacement

Rotor Rework & Replacement

13

pg. 90 Elsa 195, 225 & 250 Rotor Rework & Replacement

13 Rotor Rework & Replacement

This section explains safe working practices for the limitations of a rotor life for the ELSA-195, 225 & 250 MERITOR Inc. Air Disc Brake, with a pad back plate thickness of 9mm or above.

| Dimension Detail | 195 | 225/250 |
|---|--------|---------|
| New Rotor Thickness - A | 45mm | 45mm |
| Minimum Resurfacing Thickness | 41mm | 41mm |
| Minimum Fully Worn Thickness - B | 39mm | 39mm |
| Pad Back Plate Thickness | 9mm | 9mm |
| Carrier Rotor Gap - C | 49.3mm | 50mm |
| Minimum Friction Material Thickness | 3mm | 3mm |
| Clearance New Rotor - E | 2.15mm | 2.5mm |

New Rotor Condition Fig 13.1

The rotor nominal maximum thickness (new condition) is **A**.

The rotor gap between the carrier abutments of the brake assembly is **C** nominally.

Therefore, if the rotor is central to the carrier abutments an equal clearance of **E** nominally is achieved either side of the rotor.

However, due to tolerances the rotor is not always central to the carrier abutment gap and this may result in the rotor requiring to be replaced before being worn to the minimum thickness.

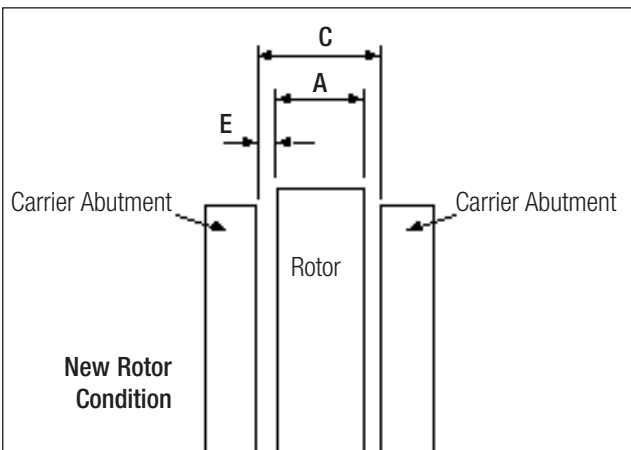

Fig. 13.1

Maximum permissible Rotor Wear Fig 13.2

The rotor is permitted to wear to a minimum thickness of **B** provided that there is maximum wear of no more than 3mm off any one rotor face. When equal wear is achieved on both sides of the rotor, the rotor maintains a central position in the carrier abutments. The rotor to carrier clearance **F** must not exceed 5.15mm (195 brakes) or 5.5mm (225/250 brakes).

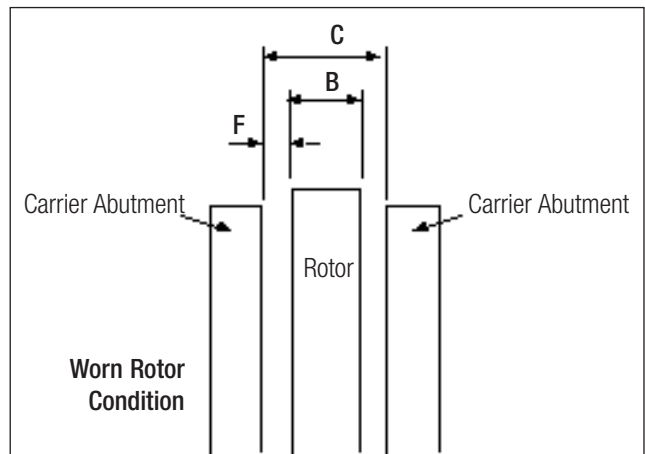

Fig. 13.2

Uneven Rotor Wear Fig 13.3

In many cases where uneven wear **D** takes place the rotor is required to be replaced before wearing down to the minimum thickness **B**. In the case of uneven rotor wear it is important that the gap between rotor and carrier abutment **F** must not exceed:

5.15mm (195 brakes)

5.5mm (225/250 brakes).

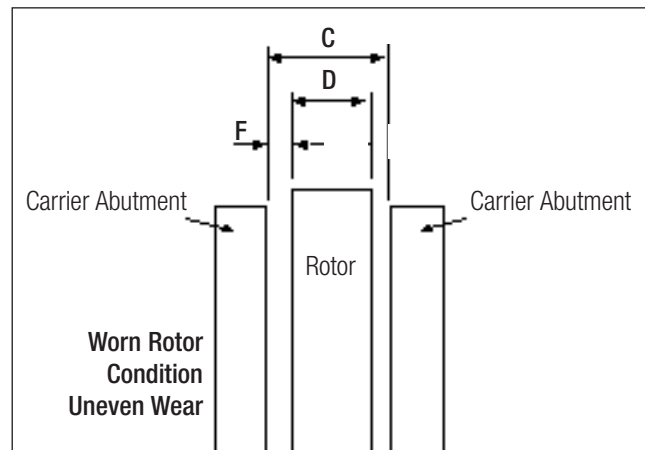

Fig. 13.3

13 Rotor Rework & Replacement



CAUTION: You must always renew the rotor on both wheels of an axle. Only use the rotors that have been approved by the vehicle manufacturer.



WARNING: To ignore these recommendations could result in severe damage to the wheel end assembly due to heat damage from metal pad back plate contacting the rotor.

To wear the pad back plate down to a thickness where it is possible to be trapped between carrier abutments and rotor could cause the wheel to lock at best and pad back plates to come out of the brake assembly at worst.

If these recommendations are not followed this negates any warranty claim and MERITOR Inc. cannot be held responsible for operator neglect.

13 Rotor Rework & Replacement

Servicing & Specifications

14

pg. 94 Servicing schedules, Tightening Torque's
pg. 95 Grease specification

14 Servicing & Specifications

Servicing

Although there is no routine maintenance of the Brake required it is important the following inspections are carried out at the periods specified, or those described in the vehicle manufacturers manual.

Every 3 months or 20,000 Km.

A visual assessment of pad life remaining should be made. Where a visual pad wear indicator is incorporated into the brake it provides a quick and simple method of assessing the pad life remaining. Brake pads should be replaced when the lining thickness has worn to 3.0 mm.

Visually inspect the general condition of the brake assembly for damage or corrosion, pay particular attention to the guide pin and piston dust excluders. If there is any doubt in the suitability for further service replace/rectify in accordance with the vehicle manufacturers recommendations.

Every 12 months

Remove the road wheels and brake pads as described in the **Section 3 Pad Replacement Section**. Inspect the guide sleeve and piston excluders and ensure they are undamaged and securely located. If any of the dust excluders are detached or damaged the relevant area of the brake should be dismantled and the components examined for corrosion or damage. Replace/rectify in accordance with the vehicle manufacturers recommendations.

Carry out the Operational Checks in Section 2 of this manual

If there is any doubt in the suitability for further service replace with new components.

Check the brake rotor for signs of heavy grooving, cracking or corrosion as shown in **Operational Checks in Section 2** and the thickness dimension is in accordance with those detailed in **Rotor rework and replacement section 13**, or the vehicle manufacturers recommendations. Replace as necessary.



CAUTION: You must always renew the brake pads on both wheels of an axle. Only use the brake pads that have been approved by the vehicle manufacturer.



CAUTION: You must always renew the rotor on both wheels of an axle. Only use rotors that have been approved by the vehicle manufacturer.



CAUTION: Take care not to trap fingers whilst checking the sliding action of the brake.



Tightening Torques

M18 Guide Sleeve Screws



CAUTION: It is important to use the correct guide sleeve tightening torque for the type of guide sleeve used in the brake assembly

Standard and Two Piece Guide Sleeves (Fig. 14.1)

(flat carrier contact surface, no ball bearings)

Preferred method is torque and angle

| | |
|--------------------|--------------------------|
| Short Guide Sleeve | 75 - 85 Nm + 90° +/- 5° |
| Long Guide Sleeve | 75 - 85 Nm + 120° +/- 5° |

Alternative method if torque and angle not possible: torque only

| | |
|--------------------|--------------|
| Short Guide Sleeve | 400 - 420 Nm |
| Long Guide Sleeve | 400 - 420 Nm |

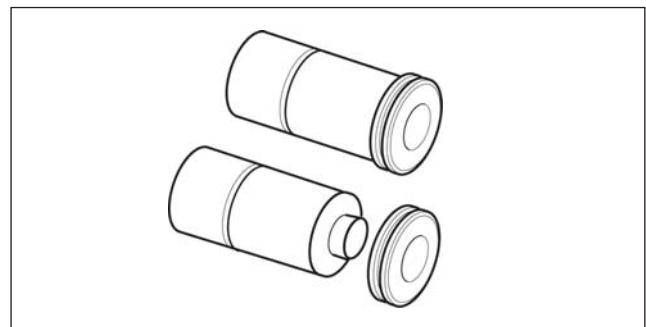

Fig. 14.1

Ball Bearing Guide Sleeves (Fig. 14.2)

(flat carrier contact surface with three ball bearings present)

Preferred method is torque and angle

| | |
|--------------------|---------------------------|
| Short Guide Sleeve | 250 - 270 Nm + 90° +/- 5° |
| Long Guide Sleeve | 250 - 270 Nm + 90° +/- 5° |

Alternative method if torque and angle not possible: torque only

| | |
|--------------------|--------------|
| Short Guide Sleeve | 465 - 485 Nm |
| Long Guide Sleeve | 465 - 485 Nm |

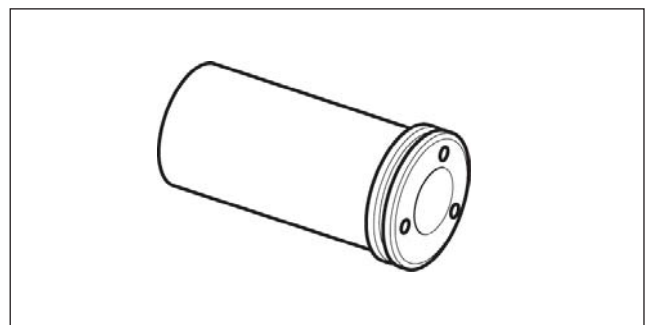

Fig. 14.2

14 Servicing & Specifications

| | |
|---|---|
| Adjuster Stem | 40 Nm Maximum |
| Pad Retaining Plate Screw | 33 - 40 Nm |
| CWS Retaining Screw | 33 - 40 Nm |
| Air Actuator Retaining Nut | |
| Pre Torque | 80 - 100 Nm |
| Final Torque | 180 - 210 Nm |
| Bridge Screws | |
| M16 Internal Hex Capscrew | 300 – 350Nm |
| M16 Torx Head Bolt | 95 - 105Nm + 75° +/- 5° |
| M14 Torx Head Bolt | 235 – 275Nm |
| M14 Torx Head Bolt (grey/silver coated bolt) | 55 - 65Nm + 100° +/- 5° |
| Rotor Shield Screws | refer to Vehicle Manufacturers recommendations |
| Pad Shield Screws | refer to Vehicle Manufacturers recommendations |
| Brake Mounting Screws | refer to Vehicle Manufacturers recommendations |

Grease

NOTE: Only use the grease supplied with replacement components/kits, or that specified by the vehicle manufacturer. Under no circumstance should any other type of grease be used.

14 Servicing & Specifications

Service Diagnosis

15

pg. 98 Service Diagnosis

15 Service Diagnosis

| Condition | Possible Cause | Check For | Corrections |
|---|---|--|--|
| | Incorrect initial adjustment | Correct pad-to-rotor clearance | Readjust to set the correct rotor-to- pad clearance |
| | Incorrect pad-to-rotor clearance | Automatic adjuster function | Replace the housing or brake assembly |
| | Spring or service brake not releasing | Correct operation of air system or air chamber | Refer to the vehicle manufacturer's instructions. Repair or replace parts as required |
| | Vehicle air system | | |
| | Air line too short | Correct air line length | Replace the air line. Refer to the vehicle manufacturer's instructions |
| | Brake not releasing | Damaged guide pin excluders; Housing should move back and forth by hand with linings removed | Replace guide pins, excluders and bushes |
| | | | Replace the housing or brake assembly |
| Water entry or seized operation shaft, internal | | Replace the housing or brake assembly and air chamber | |
| | Tappets not releasing: Damaged tappet excluders | Replace the housing or brake assembly | |
| Short brake pad lining | Refer to Brake Drag | Refer to Brake Drag | Refer to Brake Drag |
| | Damaged rotor surface | Cracks or heavy heat spotting / banding | Refer to the vehicle manufacturers instructions or brake maintenance manual. Repair or replace parts as required |
| | Vehicle overload | Refer to weight limitations on the vehicle identification plate | Observe the vehicle manufacturers load recommendations |
| | Companion brakes do not work correctly | Inspect the companion vehicle brakes and air system. | Adjust or repair as required |
| | High brake temperature | Refer to Brake Drag and Short brake pad lining life | Refer to Brake Drag and Short brake pad lining life: Can be a temporary situation with new or low mileage pads |
| | Contamination on the linings or rotor | Grease, oil, undercoating, paint, etc., on the linings or rotor | Inspect the hub seal. Replace as required |
| | | | Clean the rotor and brake assembly |
| | | Replace the axle set of pads | |

15 Service Diagnosis

| Condition | Possible Cause | Check For | Corrections |
|------------------|---|--|--|
| | Vehicle air system malfunction | Correct air pressure at the chamber inlet | Have the air system evaluated by a qualified brake system specialist |
| | Contamination on the linings or rotor | Grease, oil, undercoating, paint, etc., on the linings or rotor | Inspect the hub seal. Replace as required |
| | | | Clean the rotor and brake assembly |
| | | | Replace the axle set of pads |
| | Companion brakes not working correctly | Inspect the companion vehicle brakes and air system | Adjust or repair as required |
| | Brakes out-of-adjustment | Excessive pad-to-rotor clearance | Readjust to set the correct pad-to-rotor clearance |
| | | Automatic adjuster function | Replace the housing or brake assembly |
| | Pads not sliding in carrier / saddle | Excessive dirt / corrosion in pad locations | Clean pads and carrier / saddle locations |
| | | Excessive wear in pad locations | Fit new carrier / saddle |
| | Incorrect pads installed | Refer to the vehicle manufacturer for the correct pads | Replace the axle set of pads |
| | Brake seized or sticking on guide pins | Damaged guide pin excluders; housing should move back and forth by hand with linings removed | Replace guide pins, excluders and bushes |
| | | | Replace the housing or brake assembly |
| Vehicle overload | Refer to the weight limitations on the vehicle identification plate | Observe the vehicle manufacturer's load recommendations | |
| | Incorrect pad installation | Friction material facing the brake not the rotor surface | Correct the pad installation. Replace the pads and rotor, if necessary |
| | Incorrect pads installed | Refer to the vehicle manufacturer for the correct pads | Replace the axle set of pads |

15 Service Diagnosis

| Condition | Possible Cause | Check For | Corrections |
|----------------------------|--|--|---|
| | Brake pads not free to move in the brake | Corrosion or debris on the pads or carrier / saddle pad locations | Clean or replace the pads, if necessary. Clean the pad locations on the carrier / saddle |
| | | Excessive wear in pad locations | Fit new carrier / saddle |
| | Worn brake pads | Lining thickness | Replace the axle set of pads, if necessary |
| | Loose pads | Bent pad retainer or loose pad retainer screw | Replace or tighten the pad retainer |
| | Pad spring damaged or not installed | Correct pad spring installation | Install the pad springs |
| | Rotor cracks or excessive run-out / thickness variation | Excessive cracking, heat spotting / banding or run-out / rotor thickness variation | Refer to the vehicle manufacturer's instructions or brake maintenance manual. Repair or replace parts as required |
| | Brake component attachments are not installed to specification | Check for loose connections and fasteners | Tighten the connections and fasteners to the specified torque |
| Brake noise/ Rattle | Pad spring damaged or not installed | Broken pad springs and correct pad spring installation | Install the pad springs or replace broken springs |
| | Worn guide sleeves | Follow the procedure detailed in Operation Checks to check for excessive wear | Replace the guide sleeves and bushes |
| | | | Replace the brake assembly |
| | Worn guide sleeve bushes | Follow the procedure detailed in Operation Checks to check for excessive wear | Replace the guide sleeves and bushes |
| Replace the brake assembly | | | |

Service Tools

16

pg. 102 MST 1060 Guide Sleeve Bush removal/fitting tool

pg. 103 MST 1017 Slide Pin Wear Tool

16 Service Tools

The following tools can be purchased from Meritor Commercial Vehicle Aftermarket.

MST 1060 - Guide Sleeve Bush removal/fitting tool

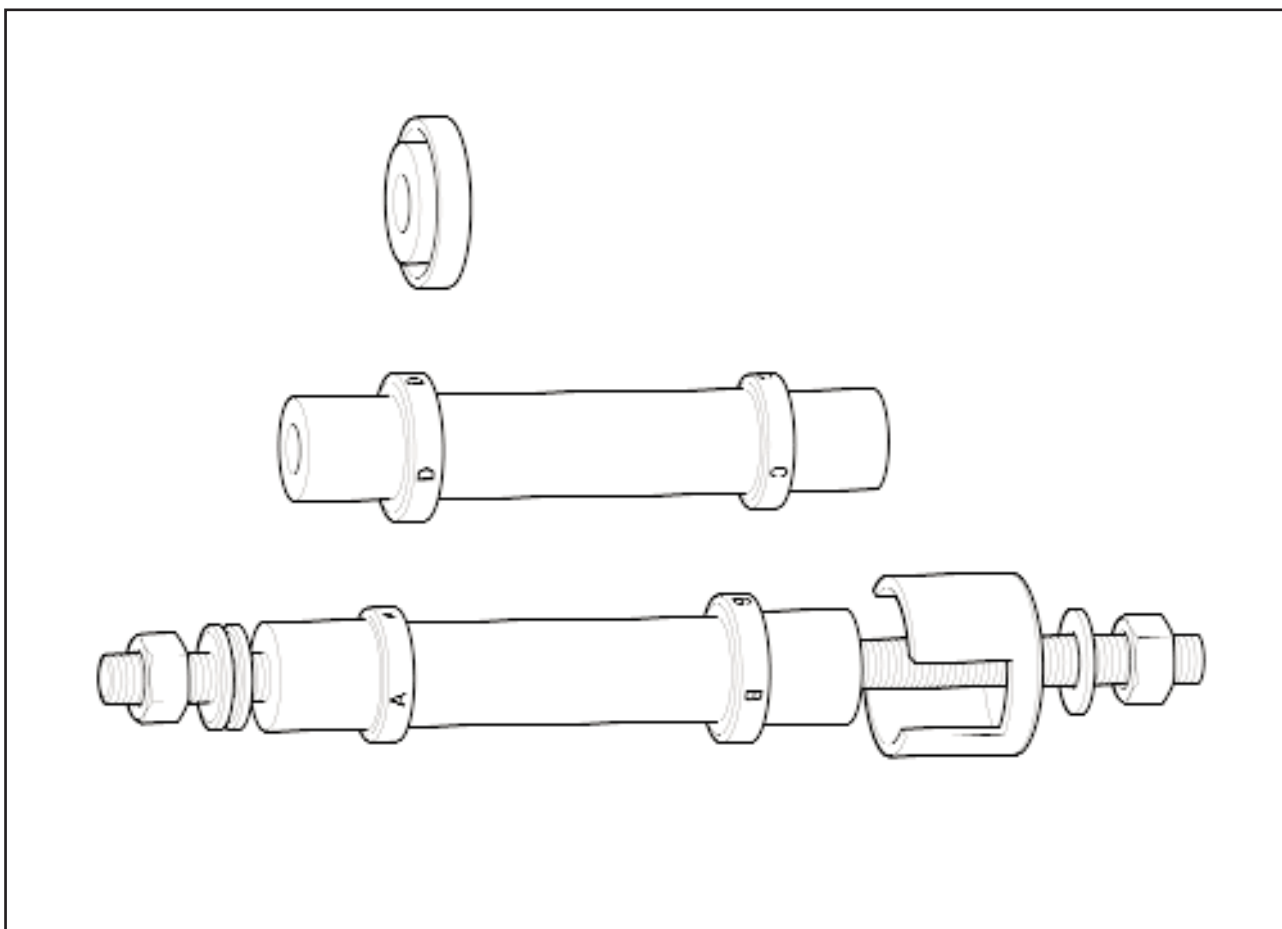

16 Service Tools

MST 1017 - Slide Pin Wear tool

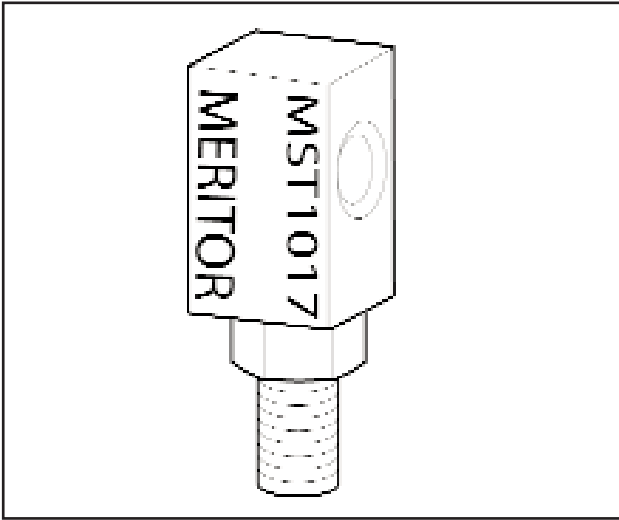

15 Service Tools

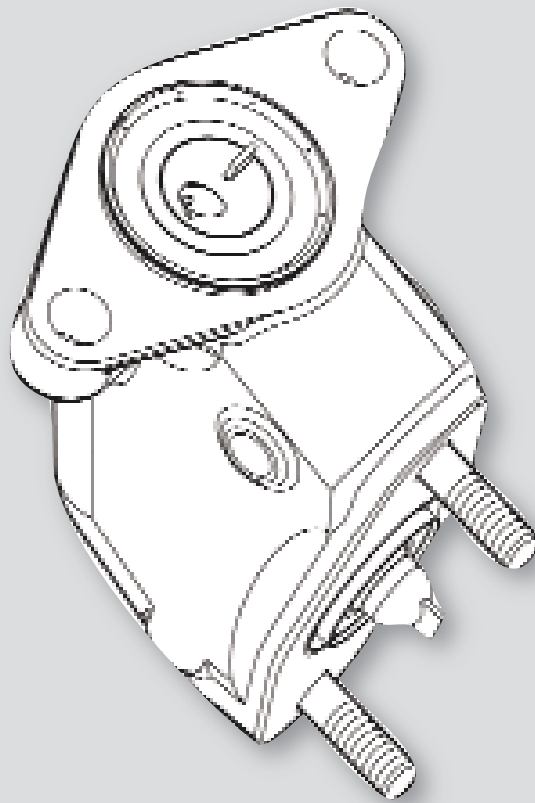

Supplement 1 Tangential Adaptor Assembly

Issued: 07/2014



All rights reserved.

No part of this publication may be reproduced in any form or by any means or granted to any third parties without the written permission of MERITOR Inc..

Information contained in this publication was in effect at the time the publication was approved for printing and is subject to change without notice or liability. MERITOR Inc. Commercial Vehicle Systems reserves the right to revise the information presented and to discontinue the production of parts described at any time.

© 2014 MERITOR Inc.

Document No. MM-0350 Supplement 1

Edition: 07/2014

Before You Begin

This publication provides installation and maintenance procedures for the Tangential Adaptor Assembly applicable to the ELSA 250 Reaction Beam Air Disc Brake.

The information contained in this publication was current at the time of printing and is subject to revision without notice or liability.

The designated trademarks are registered marks of their respective owners and MERITOR Inc. and its affiliates are not commercially connected, affiliated, or associated with any of the owners of such marks. The MERITOR Inc. products presented herein are not endorsed or authorized by any of the trademark owners.

You must understand all procedures and instructions before you begin maintenance and service procedures.

You must follow your company's maintenance and service guidelines.

You must use special tools, when required, to avoid serious personal injury and damage to components.

MERITOR Inc. uses the following notations to alert the user of possible safety issues and to provide information that will help to prevent damage to equipment and components.



WARNING

A **WARNING** indicates a procedure that you must follow exactly to avoid serious personal injury.



CAUTION

A **CAUTION** indicates a procedure that you must follow exactly to avoid damaging equipment or components.

NOTE: A note indicates an operational, procedure or instruction that is important for proper service. A NOTE can also supply information that will help to make service quicker and easier.



This symbol indicates that you must tighten fasteners to a specific torque.

Safety Instructions

- Observe the manufacturers safety instructions for jacking up and securing the vehicle
- Only use original MERITOR Inc. parts
- Use only the tools recommended
- Observe the following service instructions and notes
- Always ensure appropriate safety glasses and gloves are worn when carrying out the procedures detailed in this publication.
- When working on the brake you must ensure that it cannot be activated inadvertently
- Never use compressed air to remove brake dust or for the purpose of drying. Any type of dust can be injurious to health if inhaled. Use Meritor CVA. brake cleaner for cleaning the brake.
- When removing or fitting a complete brake, you should remember it has a dead weight of up to 108lbs (49 kg). Use a lifting system, taking care not to damage the brake.
- When the servicing has been completed, it is essential that you road test the vehicle and try out the brakes.



CAUTION: Ensure any grease removed from the assembly/components, or contaminated cloth, is disposed of in accordance with local environmental regulations.



CAUTION: You must always renew the brake pads on both wheels of an axle. Only use the brake pads that have been approved by the vehicle manufacturer.



CAUTION: Ensure any discarded friction product, or cloth contaminated with brake dust, is disposed of in accordance with local environmental regulations.



CAUTION: You must always renew the rotor on both wheels of an axle. Only use the rotors that have been approved by the vehicle manufacturer.

Access Information on MERITOR Inc.'s Web Site

Additional maintenance and service information for MERITOR Inc.'s commercial vehicle systems component lineup is also available at www.meritor.com.

To access information go to Products & Services Icon; from drop down menu click on Literature on Demand. The screen will display an index of publications by type.

Terms used in this manual

Manufacturer:

MERITOR Inc.

Manual:

Maintenance manual no. MM-0350 Supplement 1

Device:

Tangential Adaptor Assembly
(ELSA 250 Reaction Beam Air Disc Brake)

Technician:

Qualified personnel working on brake maintenance and servicing.

Maintenance and servicing:

Maintenance and servicing refer to periodical checks and/or replacement of air disc brake parts or components. It also refers to the determining of the cause of a malfunction in order to restore the initial operating conditions.

Operator:

Any person who will use the air disc brake as part of a more complex device.

Warranty

Warranty applies to the air disc brake installed on vehicles for which it was designed. Warranty is void in the following cases:

- Improper use of the vehicle on which the air disc brake is installed (usage conditions, overloading etc.)
- Tampering with vehicle components that may affect brake performance.
- Use of spare parts not approved by Meritor CVS.
- Improper installation, adjustment, repair or modification.
- Poor or improper maintenance (including consumables other than those specified).

Further information on warranty conditions may be obtained directly from the manufacturer or by referring to the MERITOR Inc. web site www.meritor.com

NOTE: The exploded and section views contained in this manual are for reference only. The internal components are not serviceable.



CAUTION: The screws A, shown below, which secure the piston housing to the brakes assembly housing **MUST NOT** be removed. Evidence of tampering with the screws will void any warranty claim.

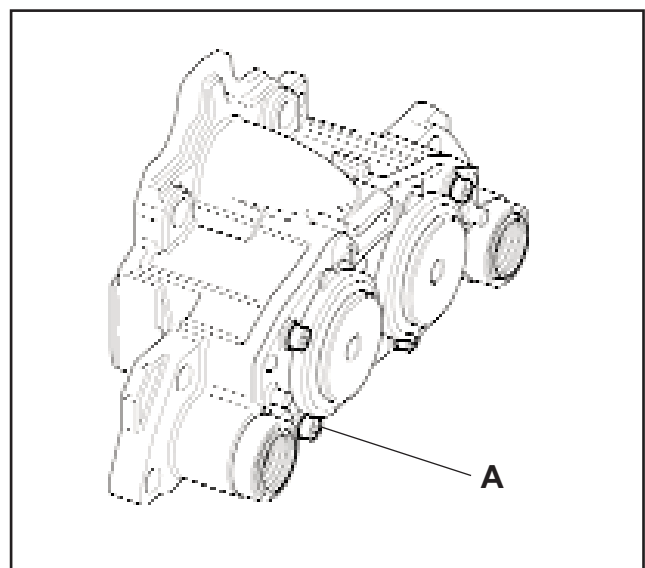

Section S1.1: Introduction

pg. 104 Exploded View & Parts List

pg. 111 Section View & Parts List

pg. 112 How it Works

Section S1.2: Adaptor Assembly Replacement

pg. 114 Assembly Removal

pg. 114 Assembly Fitment

Section S1.3: Actuator & Secondary Seal Replacement

pg. 118 Actuator Seal Replacement

pg. 119 Secondary Seal Replacement

Introduction

S1.1

pg. 110 Exploded View & Parts List

pg. 111 Section View & Parts List

pg. 112 How It Works

S1.1 Introduction

Exploded View

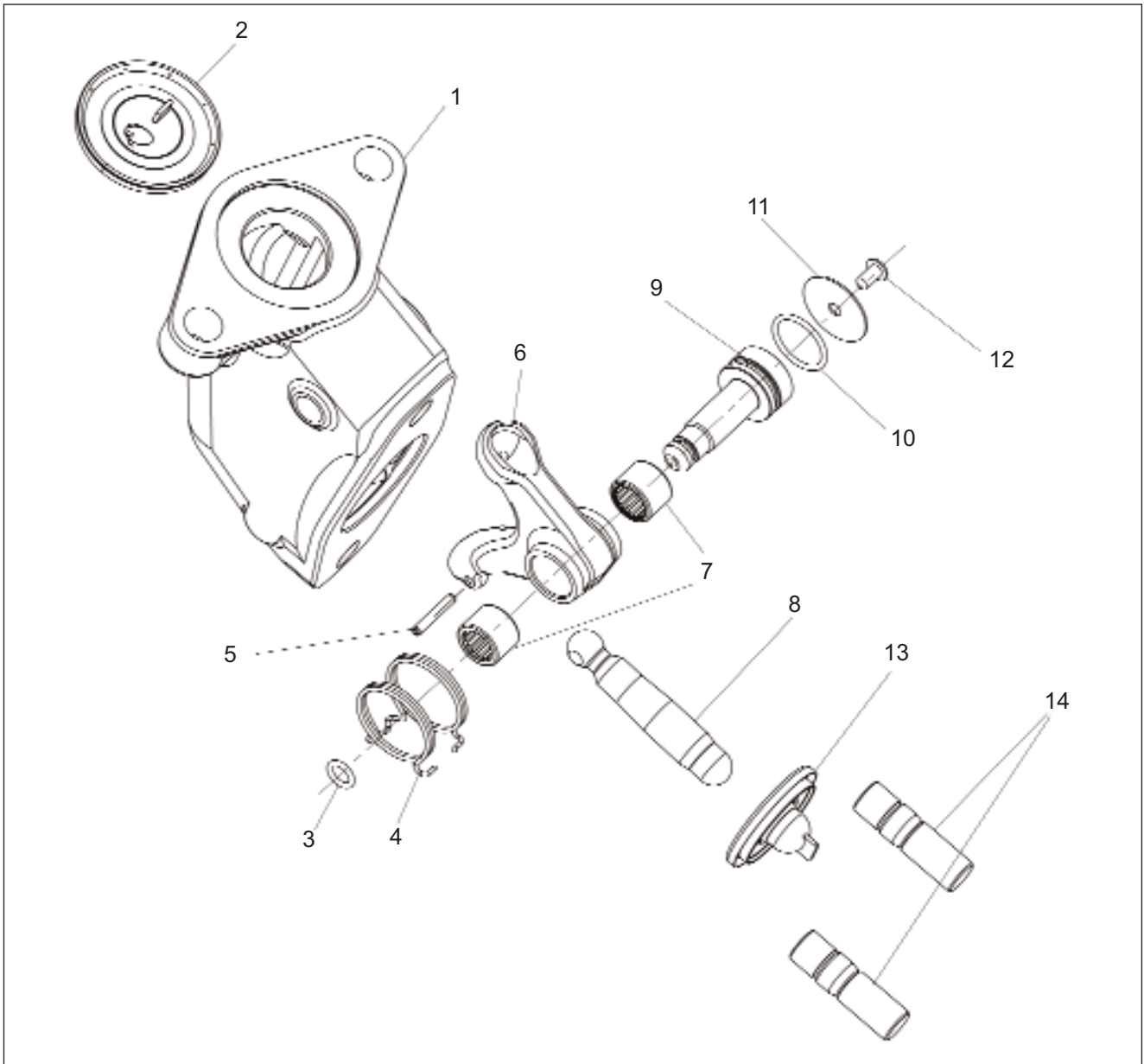

Fig S1.1.1

Parts List

| No. | DESCRIPTION | No. | DESCRIPTION |
|-----|-----------------|-----|----------------------------------|
| 1 | Housing | 8 | Link Rod |
| 2 | Actuator Seal | 9 | Pivot Shaft |
| 3 | O Ring (small) | 10 | O Ring (large) |
| 4 | Spring | 11 | Identification Disc |
| 5 | Roll Pin | 12 | Rivet |
| 6 | Operating Lever | 13 | Secondary Seal (operating shaft) |
| 7 | Needle Bearing | 14 | Mounting Stud |

S1.1 Introduction

Section View

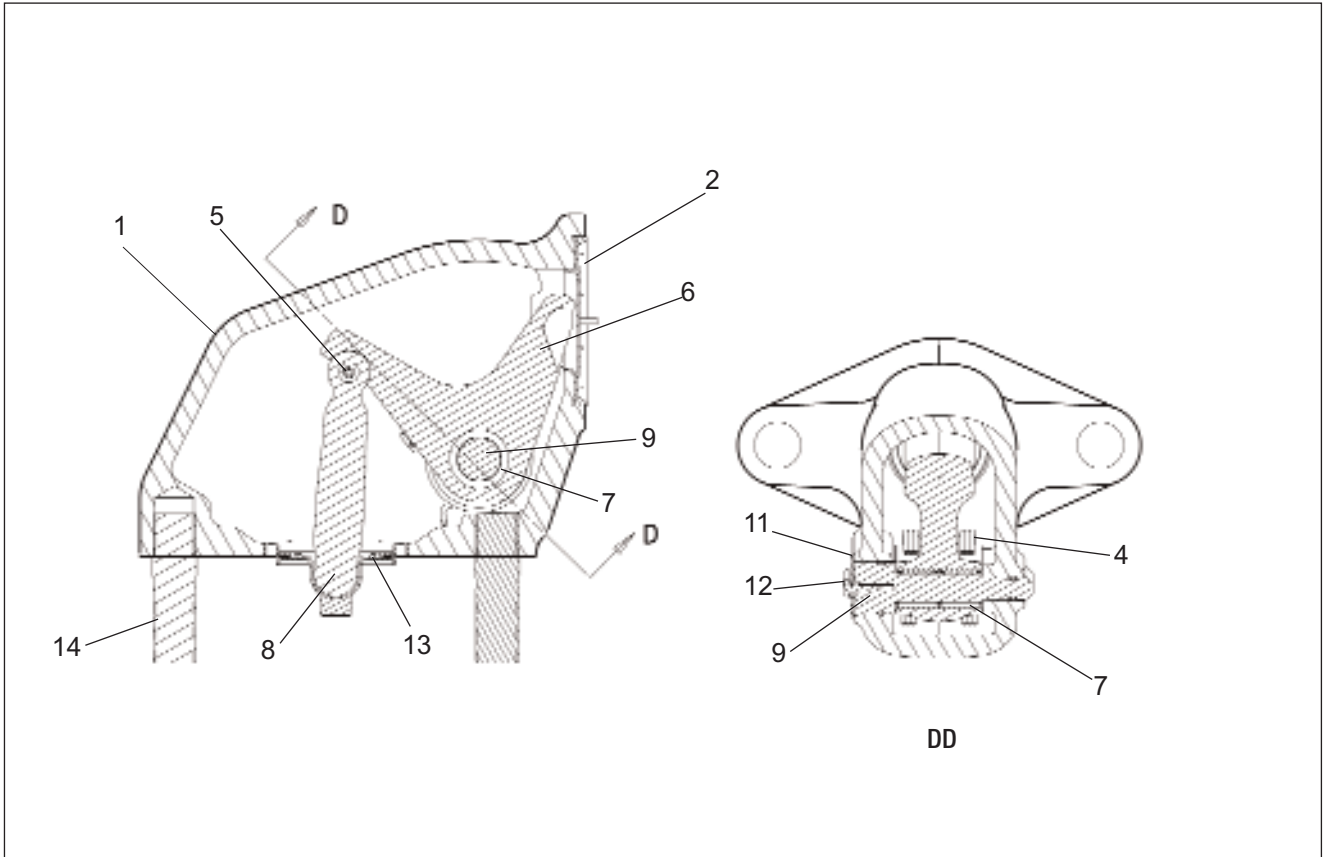

Fig S1.1.2

Parts List

| No. | DESCRIPTION | No. | DESCRIPTION |
|-----|-----------------|-----|----------------------------------|
| 1 | Housing | 8 | Link Rod |
| 2 | Actuator Seal | 9 | Pivot Shaft |
| 3 | O Ring (small) | 10 | O Ring (large) |
| 4 | Spring | 11 | Identification Disc |
| 5 | Roll Pin | 12 | Rivet |
| 6 | Operating Lever | 13 | Secondary Seal (operating shaft) |
| 7 | Needle Bearing | 14 | Mounting Stud |

S1.1 Introduction

The MERITOR Inc. Tangential adaptor assembly has been developed to be compatible with the Elsa 250 axial disc brake assembly and provide a degree of flexibility in the positioning of the air chamber within the wheel arch envelope.

The Tangential adaptor assembly is available in a variety of angle configurations, full details can be obtained from the MERITOR Inc. Technical Sales department.

The Tangential adaptor assembly has no internal service components and no attempt must be made to dismantle the assembly. The external air chamber and operating shaft interface seals are replaceable and details of this procedure can be found in **Section S3 Air Chamber & Operating Shaft Interface Seal Replacement**.

For disc brake assembly maintenance please refer to the standard Elsa 195, 225 & 250 service manual MM 0350.

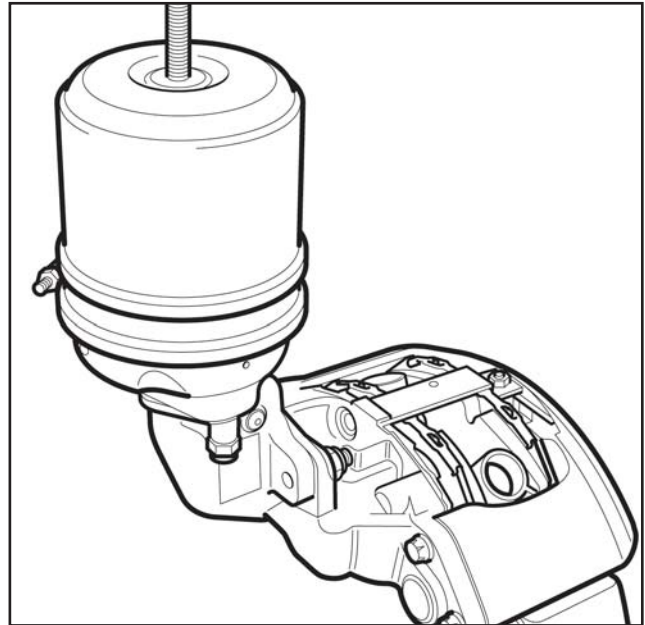

Fig S1.1.3

How It Works

The tangential adaptor assembly is secured to the brake assembly housing using the standard air chamber location flange (Fig. S1.3).

The air actuator is attached to the adaptor assembly (Fig. S1.3) and operates directly onto the internal operating lever, thus removing the necessity for the conventional external lever and linkage arrangement.

Sealing between the air actuator, adaptor assembly and brake assembly is achieved by seals located in the brake housing, adaptor assembly and actuator assembly.

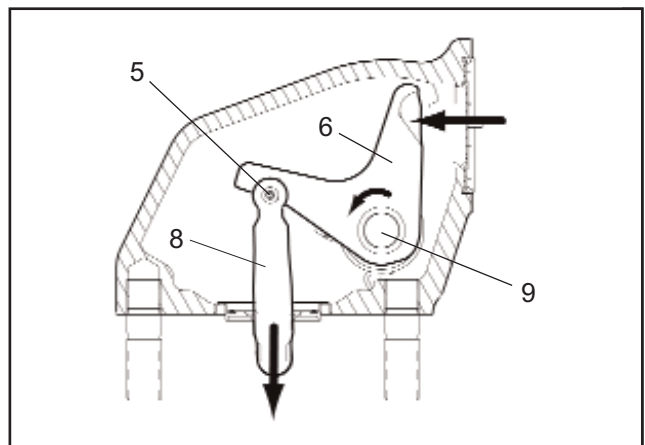

Fig S1.1.4

Brakes Applied (Fig. S1.4)

From the rest position, when air pressure is introduced into the air actuator, the push rod of the air actuator moves forward, rotating the operating lever (6) on the pivot shaft (9). The applied load is transferred to the brake assembly operating shaft by way of the link rod (8) which is secured to the operating lever with a roll pin (5).

Brakes Released (Fig. S1.5)

When the air pressure to the air actuator is released the air actuator pushrod moves backwards allowing the operating lever (6) to rotate on the pivot shaft (9) into the rest position, assisted by the two return springs (4).

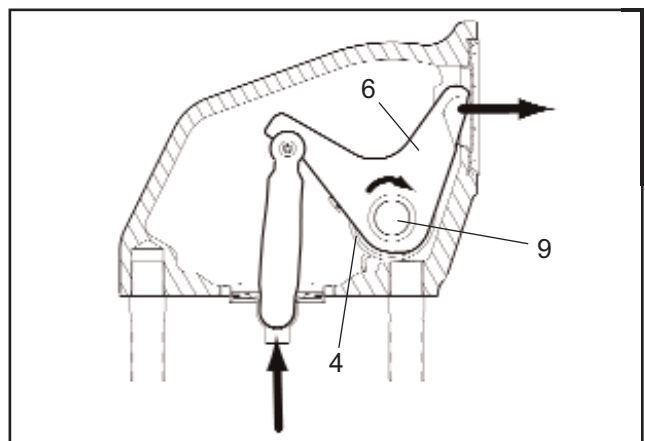

Fig S1.1.5

Adaptor Assembly Replacement

S1.2

pg. 114 Adaptor Assembly Removal

pg. 114 Adaptor Assembly Fitment

S1.2 Adaptor Assembly Replacement

Park the vehicle on level hard ground and chock the road wheels. Apply air pressure to release the park brake and wind off the spring actuator retraction screw (where appropriate). Jack up the axle and fit suitable axle stands securely. Remove the road wheels and exhaust all air from the system. Remove any dirt from the Brake assembly, ensure the rubber dust excluders are not damaged.



CAUTION: Never use an airline to blow dust from the brake/rotor area. If inhaled any form of dust can at best be an irritant, at worst dangerous. When ever possible remove dry brake dust with a vacuum brush. Alternatively wipe the areas with a damp cloth, never try to accelerate drying time by using an airline.



CAUTION: Ensure any discarded friction product, or cloth contaminated with brake dust, is disposed of in accordance with local environmental regulations.

Adaptor Assembly Removal

Remove the air actuator from the adaptor assembly by removing the 2 retaining nuts. (Fig. S2.1).

NOTE: support the air chamber under the vehicle wheel arch in a position which does not interfere with brake removal or cause undue strain on the connected air pipe.

Note the orientation of the adaptor assembly on the brake before removal.

Remove the two nuts securing the adaptor assembly to the brake housing and lift the adaptor assembly clear of the brake (Fig. S2.2)

Adaptor Assembly Fitment

Lightly grease the operating shaft pocket in the brake housing assembly with the appropriate grease. (Fig. S2.3).

NOTE: Only use the grease supplied with replacement components/kits, or that specified by the vehicle manufacturer. Under no circumstance should any other type of grease be used.

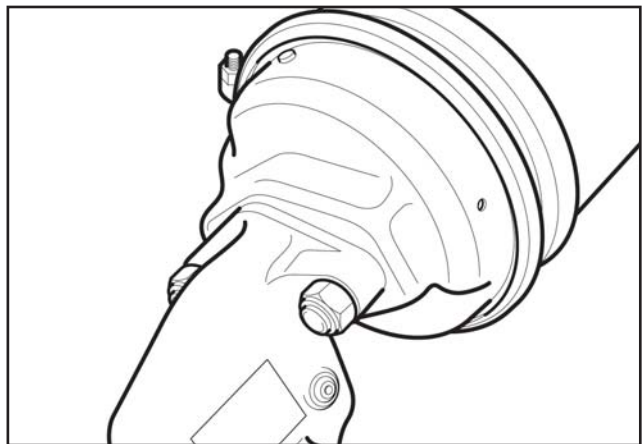

Fig S1.2.1

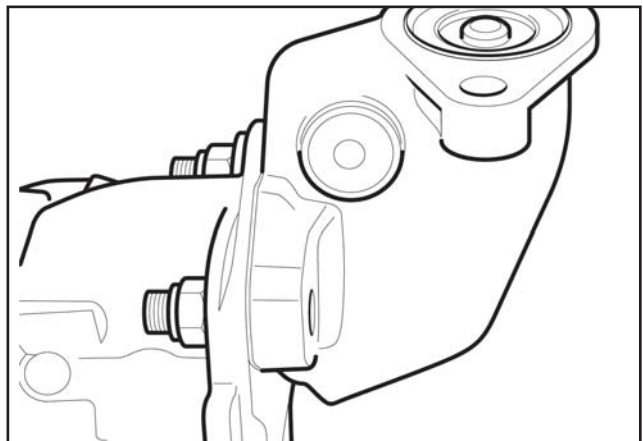

Fig S1.2.2

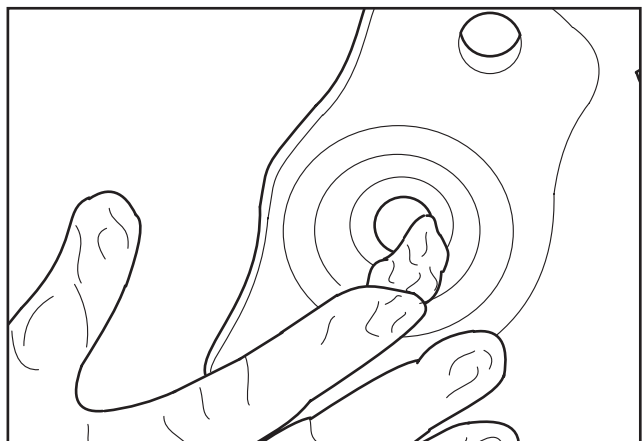

Fig S1.2.3

S1.2 Adaptor Assembly Replacement

Offer the adaptor assembly to the brake housing assembly ensuring the orientation is correct to allow fitment of the air chamber in the required position.

Ensure all mounting faces and link rod are clean and the link rod is correctly located in the operating shaft pocket.

NOTE: The transit peel out gasket **A** must be removed from the Secondary seal (Fig S2.4) before fitting the adaptor assembly to the brake housing.

T Secure the adaptor assembly to the brake housing and tighten the two retaining nuts to a torque of 180 - 210Nm.

Offer the air actuator to the adaptor assembly ensuring the mounting faces and push rod are clean and the push rod is correctly located in the operating lever pocket.

NOTE: The transit peel out gasket **A** must be removed from the Actuator seal (Fig S2.5) before fitting the Air Actuator.

T Secure the air chamber to the adaptor assembly and torque to the vehicle manufacturers recommendations.

OR

Initially tighten the 2 nuts to a pre-torque of 80 -100Nm, this ensures the actuator seals and does not distort.

Apply a final torque of 180 - 210 Nm

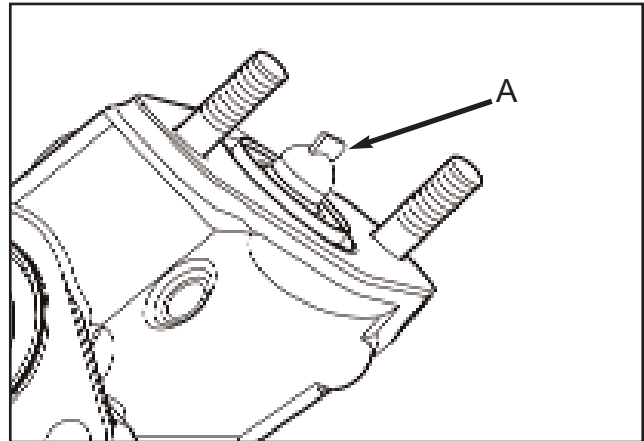

Fig S1.2.4

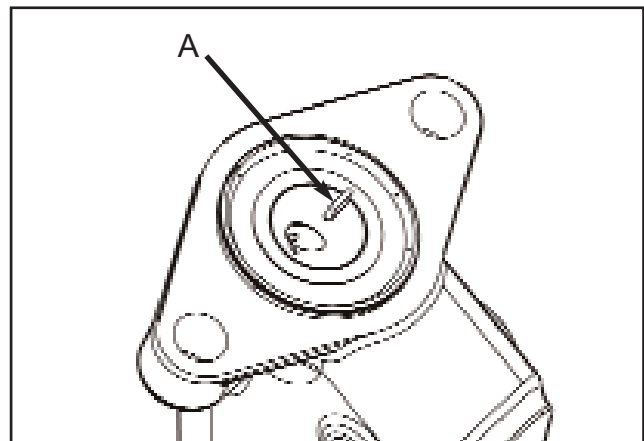

Fig S1.2.5

S1.2 Adaptor Assembly Replacement

Actuator & Secondary Seal Replacement

S1.3

pg. 118 Actuator Seal Replacement

pg. 119 Secondary Seal Replacement

S1.3 Actuator & Secondary Seal Replacement

Park the vehicle on level hard ground and chock the road wheels. Apply air pressure to release the park brake and wind off the spring actuator retraction screw (where appropriate). Jack up the axle and fit suitable axle stands securely. Remove the road wheels and exhaust all air from the system. Remove any dirt from the Brake assembly, ensure the rubber dust excluders are not damaged.

CAUTION: Never use an airline to blow dust from the brake/rotor area. If inhaled any form of dust can at best be an irritant, at worst dangerous. When ever possible remove dry brake dust with a vacuum brush. Alternatively wipe the areas with a damp cloth, never try to accelerate drying time by using an airline.

CAUTION: Ensure any discarded friction product, or cloth contaminated with brake dust, is disposed of in accordance with local environmental regulations.

Remove the air chamber and adaptor assembly as described in Section S2 Adaptor Assembly Replacement.

Actuator Seal Replacement

Secure the adaptor assembly in a suitable bench vice with the actuator seal positioned at the top.

Using a suitable screwdriver carefully lever out the actuator seal (Fig S1.3.1).

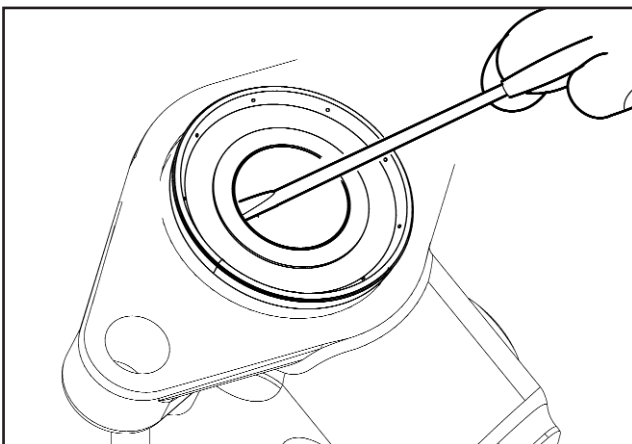

Fig S1.3.1

Clean the exposed seal location in the adaptor with a suitable Brake Cleaner and examine for damage or excessive wear.

Locate the new actuator seal in position in the adaptor face (Fig. S1.3.2).

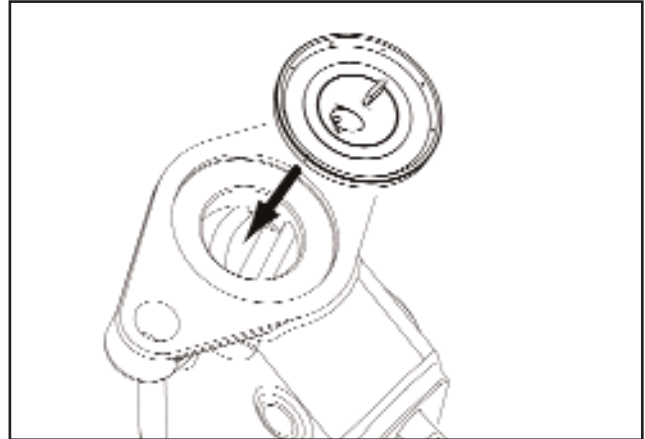

Fig S1.3.2

NOTE: Ensure the seal is fitted the correct way round when pressing into the adaptor assembly (Fig S1.3.3).

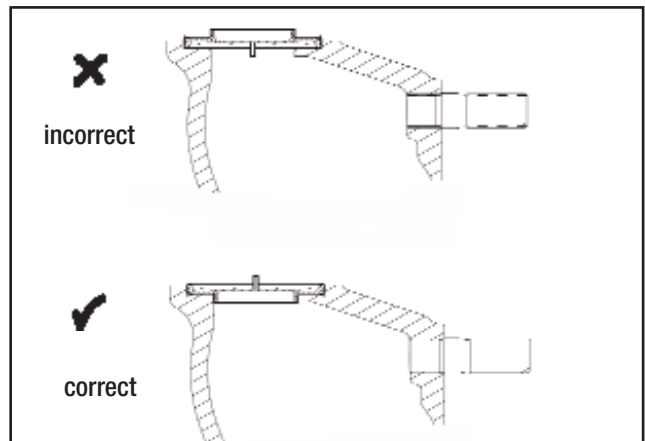

Fig S1.3.3

S1.3 Actuator & Secondary Seal Replacement

Using a suitable size socket carefully tap the seal into position (Fig S1.3.4).

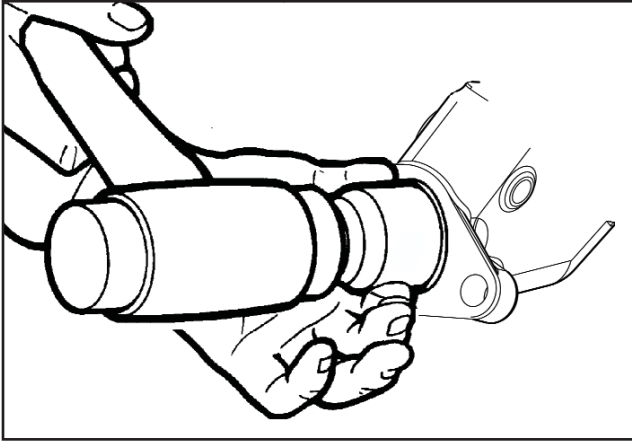

Fig S1.3.4

NOTE: The transit peel out gasket **A** must be removed from the Actuator seal (Fig S1.3.5) before fitting the Air Actuator.

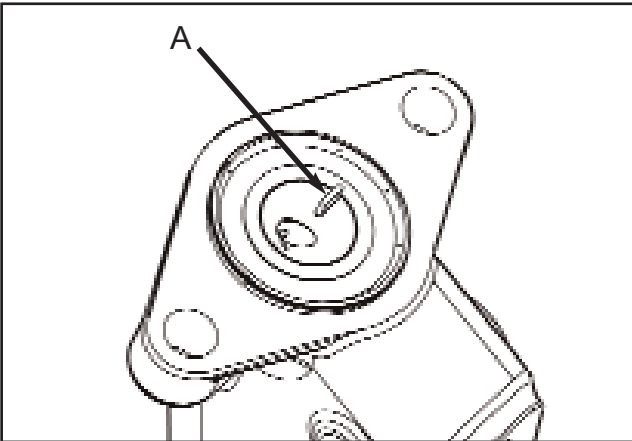

Fig S1.3.5

Secondary Seal Replacement

Remove the adaptor assembly from the bench vice and reposition with the the secondary seal face positioned at the top.

Using a suitable screwdriver carefully lever out the secondary seal .

Clean the exposed seal location in the adaptor with a suitable Brake Cleaner and examine for damage or excessive wear.

Locate the new secondary seal in position in the adaptor face (Fig. S1.3.6).

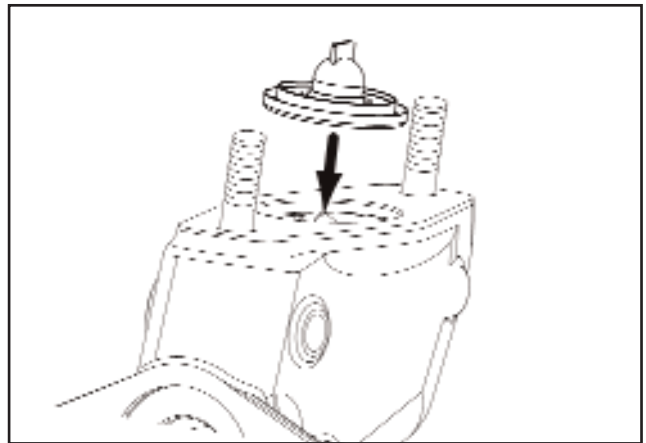

Fig S1.3.6

NOTE: Ensure the seal is fitted the correct way round when pressing into the adaptor assembly (Fig S1.3.7).

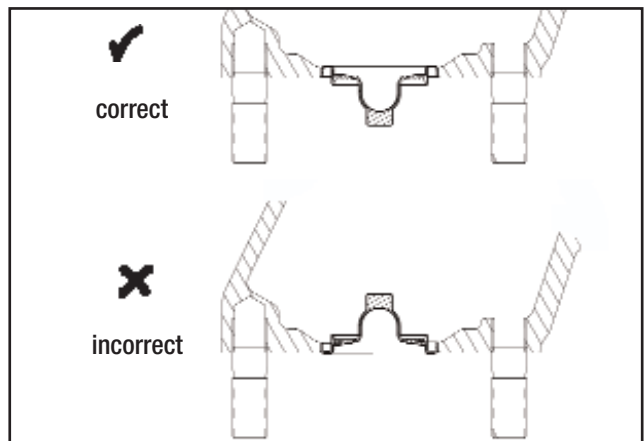

Fig S1.3.7

S1.3 Actuator & Secondary Seal Replacement

Using a suitable size socket carefully tap the seal into position (Fig S1.3.8).

NOTE: The transit peel out gasket **A** must be removed from the Secondary seal (Fig S1.3.9) before fitting the adaptor assembly to the brake housing.

Refit the air chamber and adaptor assembly as described in **Section S2 Adaptor Assembly Replacement**.

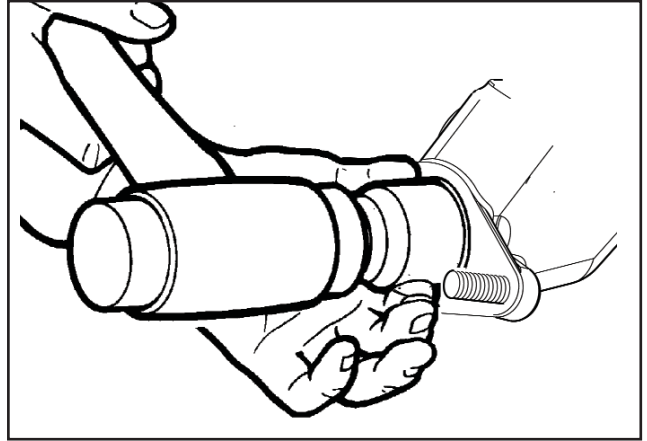

Fig S1.3.8

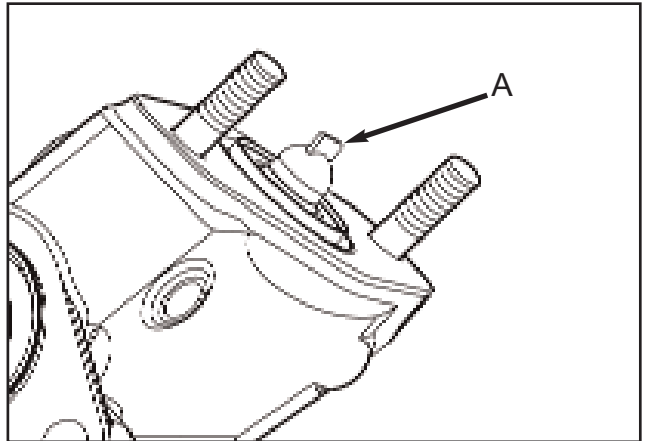
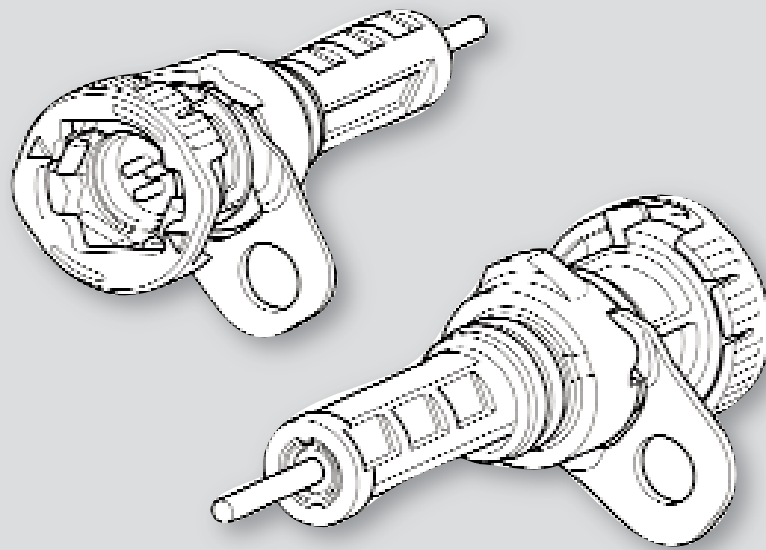

Fig S1.3.9



Supplement 2 Cartridge Continuous Wear Sensor

Issued: 03/2015



All rights reserved.

No part of this publication may be reproduced in any form or by any means or granted to any third parties without the written permission of MERITOR Inc..

Information contained in this publication was in effect at the time the publication was approved for printing and is subject to change without notice or liability. MERITOR Inc. Commercial Vehicle Systems reserves the right to revise the information presented and to discontinue the production of parts described at any time.

© 2015 MERITOR Inc.

Document No. MM-0350 Supplement 2

Edition: 03/2015

Before You Begin

This publication provides installation and maintenance procedures for the Cartridge Continuous Wear Sensor Assembly applicable to the ELSA 225H Reaction Beam Air Disc Brake.

The information contained in this publication was current at the time of printing and is subject to revision without notice or liability.

The designated trademarks are registered marks of their respective owners and MERITOR Inc. and its affiliates are not commercially connected, affiliated, or associated with any of the owners of such marks. The MERITOR Inc. products presented herein are not endorsed or authorized by any of the trademark owners.

You must understand all procedures and instructions before you begin maintenance and service procedures.

You must follow your company's maintenance and service guidelines.

You must use special tools, when required, to avoid serious personal injury and damage to components.

MERITOR Inc. uses the following notations to alert the user of possible safety issues and to provide information that will help to prevent damage to equipment and components.



WARNING

A **WARNING** indicates a procedure that you must follow exactly to avoid serious personal injury.



CAUTION

A **CAUTION** indicates a procedure that you must follow exactly to avoid damaging equipment or components.

NOTE: A note indicates an operational, procedure or instruction that is important for proper service. A NOTE can also supply information that will help to make service quicker and easier.



This symbol indicates that you must tighten fasteners to a specific torque.

Safety Instructions

- Observe the manufacturers safety instructions for jacking up and securing the vehicle
- Only use original MERITOR Inc. parts
- Use only the tools recommended
- Observe the following service instructions and notes
- Always ensure appropriate safety glasses and gloves are worn when carrying out the procedures detailed in this publication.
- When working on the brake you must ensure that it cannot be activated inadvertently
- Never use compressed air to remove brake dust or for the purpose of drying. Any type of dust can be injurious to health if inhaled. Use Meritor CVA. brake cleaner for cleaning the brake.
- When removing or fitting a complete brake, you should remember it has a dead weight of up to 108lbs (49 kg). Use a lifting system, taking care not to damage the brake or cartridge wear sensor.
- When the servicing has been completed, it is essential that you road test the vehicle and try out the brakes.



CAUTION: When the brake assembly is removed from the vehicle, particular care must be taken to ensure the cartridge wear sensor is not damaged when handling or servicing on the workbench. Ensure the brake assembly rests on the bridge, not on the actuator side as shown below.

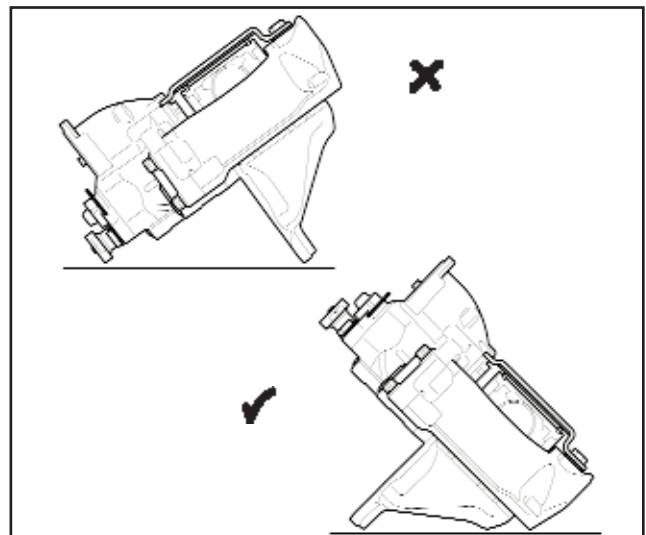

Service Notes



CAUTION: Ensure any grease removed from the assembly/components, or contaminated cloth, is disposed of in accordance with local environmental regulations.



CAUTION: You must always renew the brake pads on both wheels of an axle. Only use the brake pads that have been approved by the vehicle manufacturer.



CAUTION: Ensure any discarded friction product, or cloth contaminated with brake dust, is disposed of in accordance with local environmental regulations.



CAUTION: You must always renew the rotor on both wheels of an axle. Only use the rotors that have been approved by the vehicle manufacturer.

Access Information on MERITOR Inc.'s Web Site

Additional maintenance and service information for MERITOR Inc.'s commercial vehicle systems component lineup is also available at www.meritor.com.

To access information go to Products & Services Icon; from drop down menu click on Literature on Demand. The screen will display an index of publications by type.

Terms used in this manual

Manufacturer:

MERITOR Inc.

Manual:

Maintenance manual no. MM-0350 Supplement 2

Device:

Cartridge continuous wear sensor
(ELSA 225H Reaction Beam Air Disc Brake)

Technician:

Qualified personnel working on brake maintenance and servicing.

Maintenance and servicing:

Maintenance and servicing refer to periodical checks and/or replacement of air disc brake parts or components. It also refers to the determining of the cause of a malfunction in order to restore the initial operating conditions.

Operator:

Any person who will use the air disc brake as part of a more complex device.

Warranty

Warranty applies to the air disc brake installed on vehicles for which it was designed. Warranty is void in the following cases:

- Improper use of the vehicle on which the air disc brake is installed (usage conditions, overloading etc.)
- Tampering with vehicle components that may affect brake performance.
- Use of spare parts not approved by Meritor CVS.
- Improper installation, adjustment, repair or modification.
- Poor or improper maintenance (including consumables other than those specified).

Further information on warranty conditions may be obtained directly from the manufacturer or by referring to the MERITOR Inc. web site www.meritor.com

NOTE: The exploded and section views contained in this manual are for reference only. The internal components are not serviceable.



CAUTION: The screws A, shown below, which secure the piston housing to the brakes assembly housing **MUST NOT** be removed. Evidence of tampering with the screws will void any warranty claim.

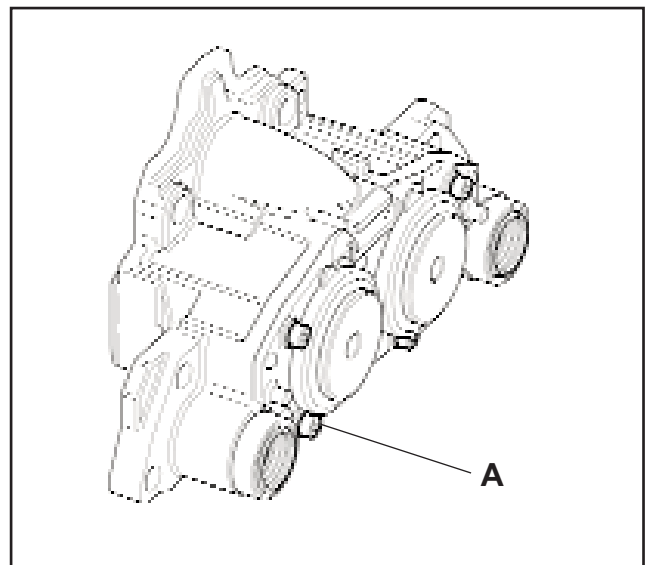

Section S2.1: Introduction

pg. 126 Exploded View & Parts List

pg. 127 Introduction

pg. 127 How it Works

Section S2.2: CWS Assembly Removal & Replacement

pg. 130 Removing and Refitting the Original Sensor

pg. 131 Original Sensor Replacement

Introduction

S2.1

pg. 126 Exploded View & Parts List

pg. 127 Introduction

pg. 127 How It Works

S2.1 Introduction

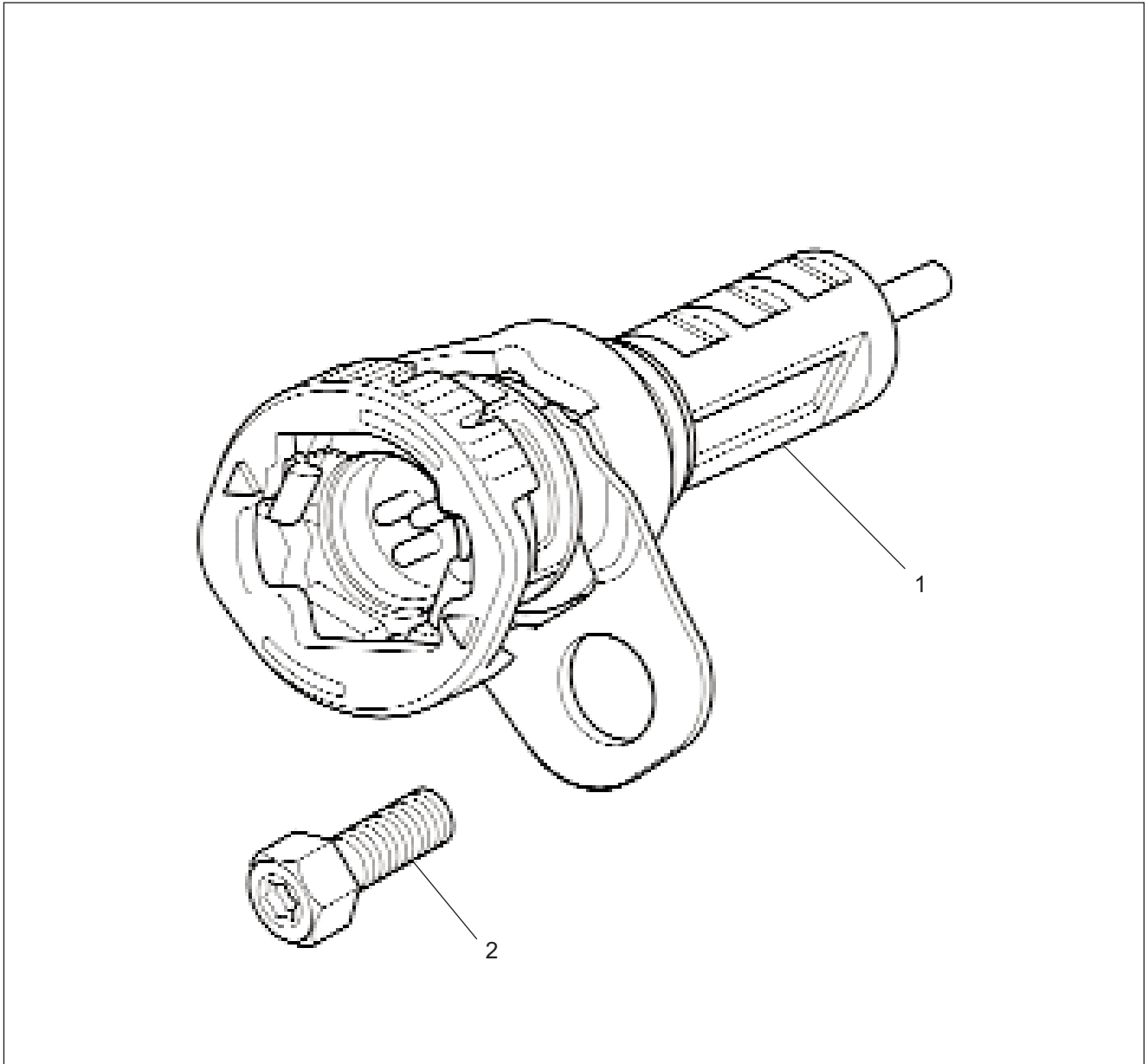

Fig S2.1.1

| No. | DESCRIPTION |
|-----|------------------|
| 1 | Cartridge Sensor |
| 2 | Retaining Screw |

S2.1 Introduction

For disc brake assembly maintenance please refer to the standard Elsa 195, 225 & 250 service manual MM 0350.

The Elsa 225H disc brake assembly incorporates a new cartridge design continuous wear sensor.

The new design cartridge sensor is easily identified as it incorporates a harness connector locking collar (Fig. S2.1.2) and does not include an integral wiring harness (Fig. S2.1.3).

The new cartridge design wear sensor provides the facility for the vehicle harness to be connected directly to the sensor.

The cartridge design operates in exactly the same way as earlier design sensors, and constantly monitors the distance across the pads and the rotor, allowing the system to monitor and adjust brake balance as pad wear across the axle is recorded.

Operation (Fig.2.1.4)

The wear sensor (24) is driven by an arm (45) that runs up and down a fine thread on the manual adjuster stem (31). The arm cannot rotate within the housing (3) and as adjustment of the brake mechanism occurs, the manual adjuster stem (31) rotates and the arm travels along the length of the shaft, driving the sensor.

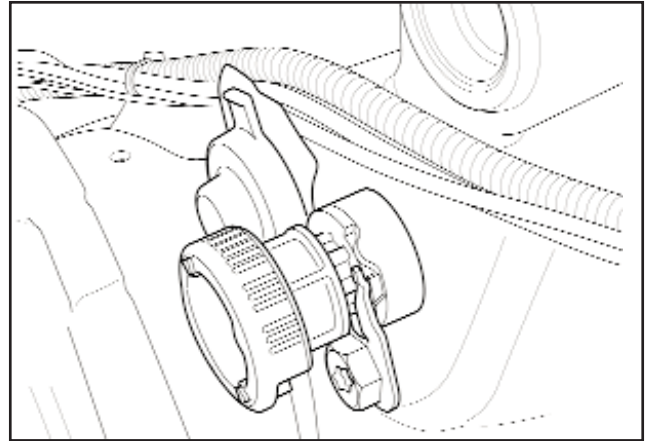

Fig S2.1.2

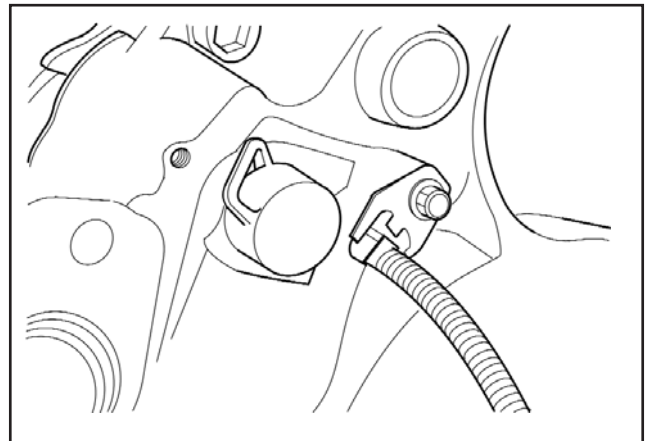

Fig S2.1.3

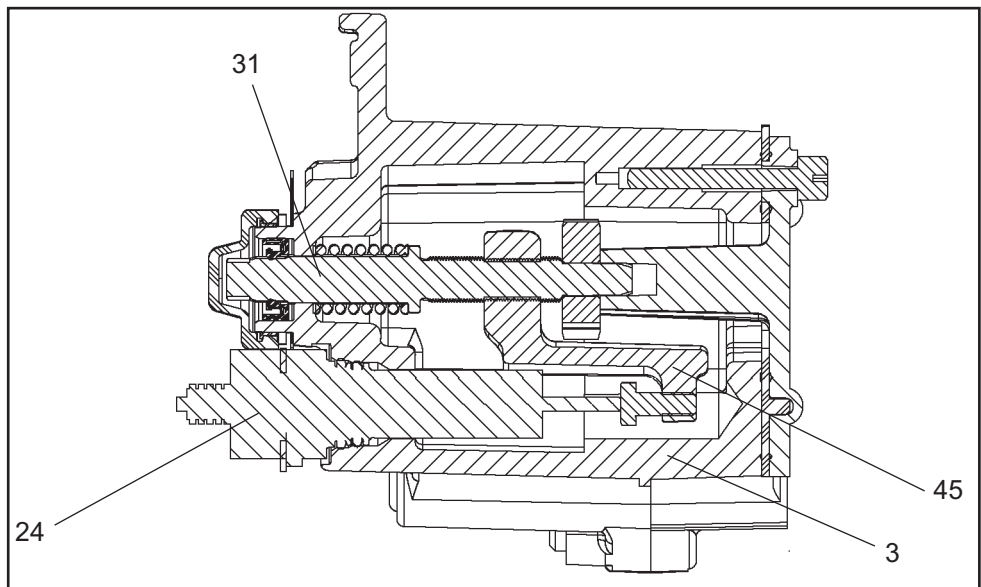

Fig S2.1.4

S2.1 Introduction

Wear Sensor Removal & Replacement

S2.2

pg. 130 Removing and Refitting the Original Sensor
pg. 131 Original Sensor Replacement

S2.2 CWS (Sensor) Replacement

Park the vehicle on hard ground and chock the road wheels. Apply air pressure to release the park brake and wind off the spring brake retraction bolt (where appropriate). Jack up the axle and fit suitable axle stands securely.

Remove the road wheels and exhaust all air from the system. Remove any dirt from the brake assembly, ensure the rubber dust excluders are not damaged.



CAUTION: Never use an air line to blow dust from the brake/rotor area. If inhaled any form of dust can at best be an irritant, at worst dangerous. When ever possible remove dry brake dust with a vacuum brush. Alternatively wipe the areas with a damp cloth, never try to accelerate drying time by using an air line.



CAUTION: Ensure any discarded friction product, or cloth contaminated with brake dust, is disposed of in accordance with local environmental regulations.

NOTE: The procedure for removing and refitting the original sensor, to allow subsequent brake assembly servicing, and the replacement of the original sensor with a new sensor assembly are different. Follow the appropriate instructions below.

Removing and Refitting the Original Sensor

NOTE: When removing and refitting the original CWS it is not necessary to disconnect the **vehicle wiring harness connector from the sensor**.

Sensor removal

Clean off any road dirt in the area of the sensor.

Remove the wear sensor retaining screw **A** (Fig. 2.2.1).

Do not release the locking ring **B** (Fig. 2.2.1).

Carefully lever out the wear sensor, as shown in Fig. 2.2.2.



CAUTION: Do not pull the vehicle wiring harness when removing the sensor .

Sensor refitting

Clean the sensor access hole and mounting face on the housing and ensure no debris is allowed to fall into the exposed aperture in the housing.

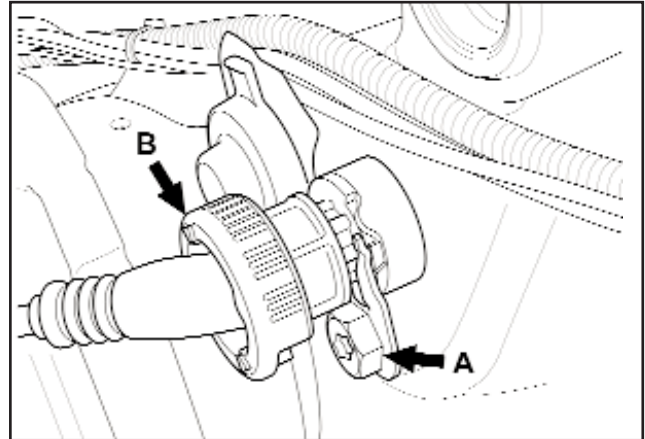

Fig S2.2.1

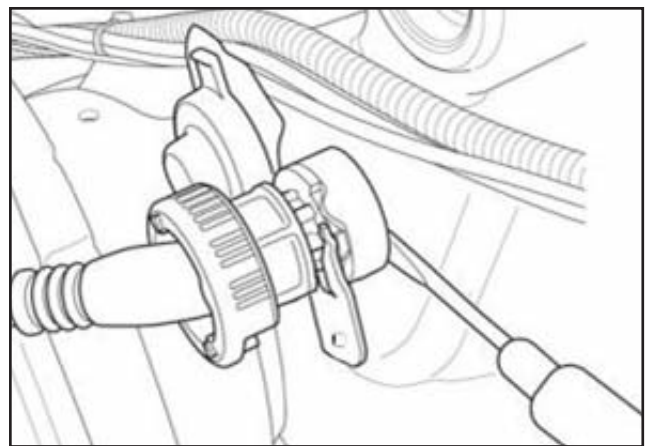

Fig S2.2.2

Ensure the 'O' ring seals are clean and free of debris. Lightly grease the 'O' ring seal on the sensor.

NOTE: Only use the grease supplied with replacement components/kits, or that specified by the vehicle manufacturer. Under no circumstance should any other type of grease be used.

Refit the sensor into the housing keeping the sensor level as it enters the housing aperture. This will ensure the sensor stem locates correctly on the screw head of the manual adjuster.

NOTE: Ensure the adjuster dust excluder retaining strap and the brake ID label are not trapped under the sensor.

Refit the retaining screw **A** (Fig. 2.2.1) and tighten to $35\text{Nm} \pm 5\text{Nm}$.

S2.2 CWS (Sensor) Replacement

Original Sensor Replacement

Sensor Cartridge Removal

Locate the sensor locking collar and, by hand, carefully turn it in a clockwise direction approximately 20 to 30 degrees to the unlocked position (Fig. 2.2.3).

NOTE: When the locking collar reaches its unlocked position it should be possible to feel a positive click.



CAUTION: Always unlock/lock the sensor locking collar carefully by hand. NEVER use grips or any other tools. The use of grips or other tools could result in damage to the sensor locking collar resulting in insufficient retention of the vehicle wiring harness connector.

Remove the vehicle wiring harness connector from the sensor assembly (Fig. 2.2.4).

Remove the sensor retaining screw and discard. Carefully lever out the sensor assembly (Fig 2.2.5) and discard.



Fig S2.2.3

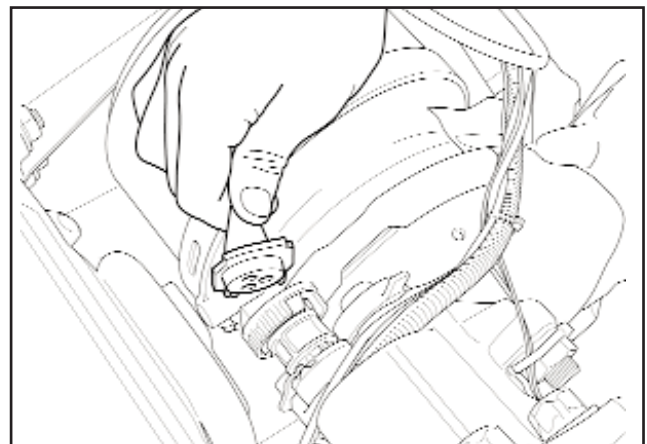

Fig S2.2.4

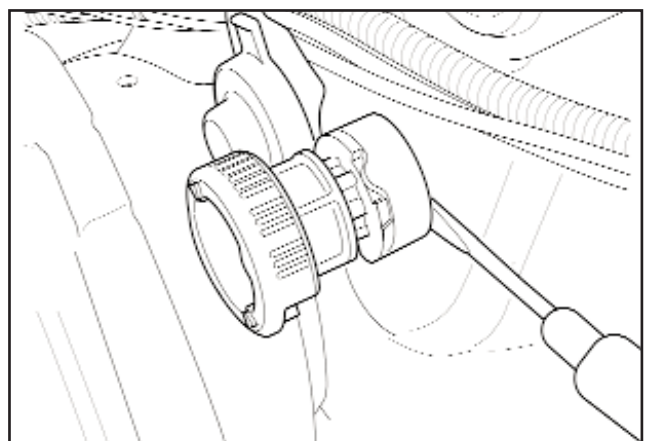

Fig S2.2.5

S2.2 CWS (Sensor) Replacement

New Sensor Cartridge Fitment

Clean the sensor access hole and mounting face on the housing and ensure no debris is allowed to fall into the exposed aperture into the housing.

Ensure the sensor locking collar is in the unlocked position (Fig. 2.2.6)

Lightly grease the two 'O' ring seals on the new cartridge pad wear sensor. Fit the new sensor into the housing keeping the sensor level as it enters the housing aperture, this will ensure that the sensor stem locates correctly on the screw head of the manual adjuster.

NOTE: Only use the grease supplied with replacement components/kits, or that specified by the vehicle manufacturer. Under no circumstance should any other type of grease be used.

NOTE: Ensure the adjuster dust excluder retaining strap and the brake ID label are not trapped under the sensor.

Fit the new retaining screw and tighten to 33 - 40Nm (Fig. 2.2.7).



CAUTION: The retaining screw for the cartridge design sensor assembly is shorter in length than the retaining screw for standard sensor assembly. It is easily identified as it has a hexagonal head with internal Torx feature (Fig. 2.2.7). Always ensure the correct retaining screw is used. The use of any other screw may compromise the retention of the sensor assembly.

NOTE: It is important to offer the vehicle wiring harness connector to the sensor in the correct orientation. Failure to do this will prevent the harness connector to be attached to the sensor.

Fig. 2.2.8 shows the correct orientation of the harness connector and position of the location pips **A** for front and rear brake installations. For front brakes (left hand & right hand) the location pips **A** must face down, when looking at the face of the harness connector.

For rear brakes the location pips **A** must face towards the rear of the vehicle, when looking at the face of the harness connector.

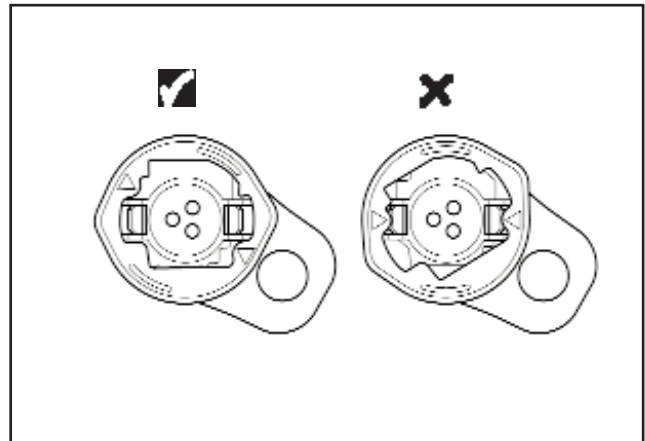

Fig S2.2.6

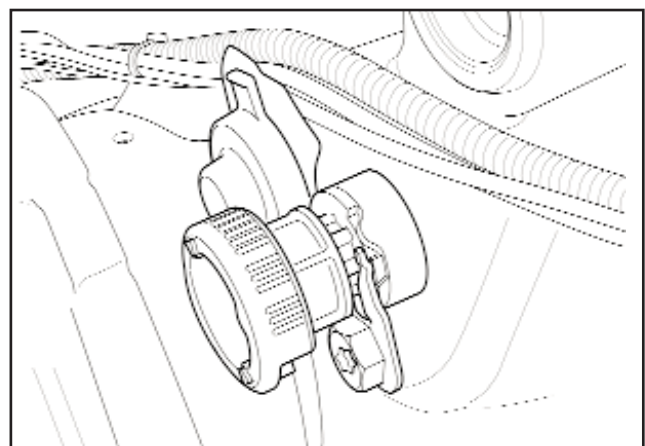

Fig S2.2.7

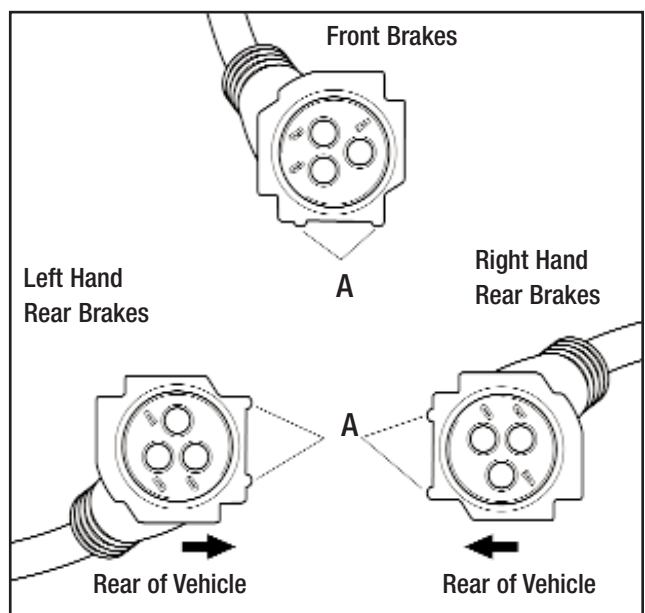

Fig S2.2.8

S2.2 CWS (Sensor) Replacement

Refit the vehicle wiring harness connector to the sensor assembly (Fig. 2.2.9)

By hand, carefully turn the sensor locking collar in an anti-clockwise direction approximately 20 to 30 degrees to the locked position (Fig. 2.2.10).

NOTE: When the locking collar reaches its locked position it should be possible to feel a positive click.

Check that the sensor assembly is functioning by observing the readout on the vehicle instrument panel.



CAUTION: Always unlock/lock the sensor locking collar carefully by hand. NEVER use grips or any other tools. The use of grips or other tools could result in damage to the sensor locking collar resulting in insufficient retention of the vehicle wiring harness connector.

Charge the system with air. Wind in the spring brake retraction bolt (where applicable). Refit the road wheels, remove the axle stands and lower the vehicle to the ground.

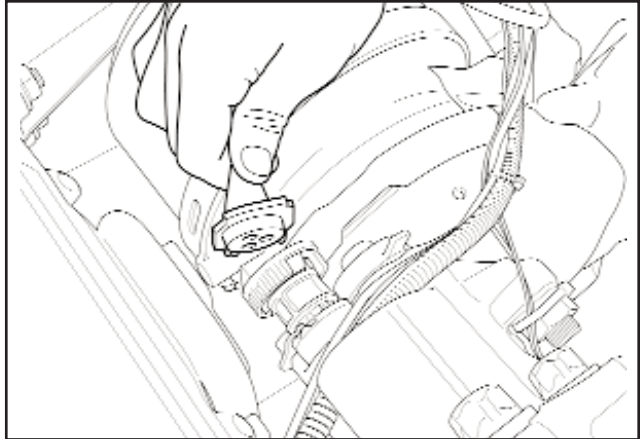

Fig S2.2.9

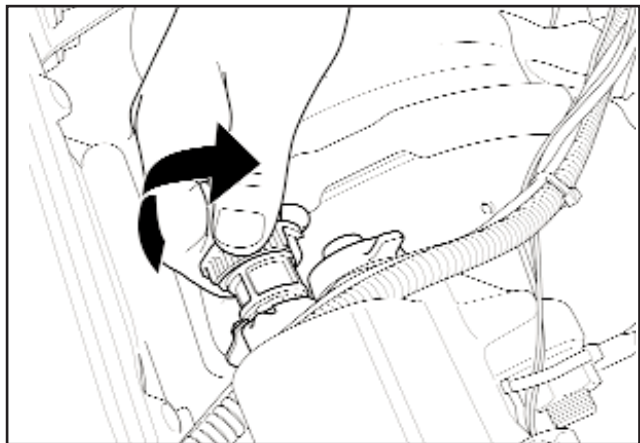

Fig S2.2.10

FOR FURTHER INFORMATION CONTACT

Meritor Inc.
Grange Road, Cwmbran
Torfaen NP44 3XU - UK
Tel +44 (0)1633 834 040

Meritor Commercial
Vehicle Aftermarket AG
Neugutstrasse 89
8600 Dubendorf
Switzerland
Tel +41 44 824 8200



Meritor Heavy Vehicle Systems, LLC
2135 West Maple Road
Troy, Michigan 48084 USA

For more information,
call OnTrac at 866-668-7221
or visit MERITOR.COM.

Descriptions and specifications were in effect at the time of this publication and are subject to change without notice or liability. Meritor reserve the right to make design improvements, change or discontinue parts at any time.